

Low Loss Header Series

Installation and Commissioning Guide

Table of Contents

Introduction.....	4
Components.....	5-7
Operation.....	8
Technical Data.....	9-12
Wiring.....	13
Commissioning.....	14
Warranty.....	15

This User Guide is Applicable to:

Low Loss Header Boiler Panels (DHW Priority)

T-LL-BD-1100	Low Loss Header Panel with UPS 15-58 Pumps, (1) Boiler Pump and (1) DHW Zone with Priority
T-LL-BD-1110	Low Loss Header Panel with UPS 15-58 Pumps, (1) Boiler Pump, (1) High Temp Zone and (1) Low Temp Zone
T-LL-BD-2100	Low Loss Header Panel with (1) 26-99 Boiler Pump and (1) DHW Zone
T-LL-BD-2100 26-99	Low Loss Header Panel with (1) 26-99 Boiler Pump and (1) 26-99 DHW Zone
T-LL-BD-2110	Low Loss Header Panel with (1) 26-99 Boiler Pump, (1) DHW Zone with Priority and (1) Low Temp Zone
T-LL-BD-2200	Low Loss Header Panel with (1) 26-99 Boiler Pump and (1) DHW Zone

Low Loss Header Boiler Panels (DHW Priority)

T-LL-BO-1010	Low Loss Header Panel with UPS 15-58 Pumps, (1) Boiler Pump and (1) Low Temp Zone
T-LL-BO-1020	Low Loss Header Panel with UPS 15-58 Pumps, (1) Boiler Pump and (2) Low Temp Zones
T-LL-BO-1100	Low Loss Header Panel with UPS 15-58 Pumps, (1) Boiler Pump and (1) High Temp Zone
T-LL-BO-1200	Low Loss Header Panel with UPS 15-58 Pumps, (1) Boiler Pump and (2) High Temp Zone
T-LL-BO-1300	Low Loss Header Panel with UPS 15-58 Pumps, (1) Boiler Pump and (3) High Temp Zone
T-LL-BO-1110	Low Loss Header Panel with UPS 15-58 Pumps, (1) Boiler Pump, (1) High Temp Zone and (1) Low Temp Zone (1) TMV
T-LL-BO-2010	Low Loss Header Panel with (1) 26-99 Boiler Pump and (1) Low Temp Zone
T-LL-BO-2020	Low Loss Header Panel with (1) 26-99 Boiler Pump and (2) Low Temp Zones

Low Loss Header Panels

T-LL-0D-0100	Low Loss Header Panel with (1) DHW Zone
T-LL-0D-0110	Low Loss Header Panel with (1) High Temp Zone and (1) Low Temp Zone
T-LL-0D-0120	Low Loss Header Panel with (1) TMV, (1) DHW Zone with Priority and (2) Low Temp Zones
T-LL-0D-0130	Low Loss Header Panel with (1) DHW Zone with Priority and (3) Low Temp Zones
T-LL-0D-0200	Low Loss Header Panel with (1) DHW Zone with Priority and (1) High Temp Zones
T-LL-0D-0210	Low Loss Header Panel with (1) TMV, (1) DHW Zone with Priority, (1) Hi Temp Zone and (1) Low Temp Zone
T-LL-00-0110	Low Loss Header Panel with (1) High Temp Zone and (1) Low Temp Zone
T-LL-00-0120	Low Loss Header Panel with (1) High Temp Zone and (2) Low Temp Zones
T-LL-00-0210	Low Loss Header Panel with (2) High Temp Zones and (1) Low Temp Zone
T-LL-00-0100	Low Loss Header Panel with (1) High Temp Zone
T-LL-00-0200	Low Loss Header Panel with (2) High Temp Zones
T-LL-00-0300	Low Loss Header Panel with (3) High Temp Zones
T-LL-00-0400	Low Loss Header Panel with (4) High Temp Zones

Low Loss Header Panels with an Expansion Module

<i>T-LL-EX-0100</i>	Low Loss Header with an Expansion Module and (1) Hi Temp Zone
<i>T-LL-EX-0200</i>	Low Loss Header with an Expansion Module and (2) Hi Temp Zones
<i>T-LL-EX-0300</i>	Low Loss Header with an Expansion Module and (3) Hi Temp Zones
<i>T-LL-EX-0400</i>	Low Loss Header with an Expansion Module and (4) Hi Temp Zones
<i>T-LL-EX-0500</i>	Low Loss Header with an Expansion Module and (5) Hi Temp Zones
<i>T-LL-EX-0010</i>	Low Loss Header with an Expansion Module and (1) Low Temp Zone
<i>T-LL-EX-0020</i>	Low Loss Header with an Expansion Module and (2) Low Temp Zones
<i>T-LL-EX-0030</i>	Low Loss Header with an Expansion Module and (3) Low Temp Zones
<i>T-LL-EX-0040</i>	Low Loss Header with an Expansion Module and (4) Low Temp Zones
<i>T-LL-EX-0050</i>	Low Loss Header with an Expansion Module and (5) Low Temp Zones
<i>T-LL-EX-0110</i>	Low Loss Header with an Expansion Module, (1) High Temp Zone and (1) Low Temp Zone
<i>T-LL-EX-0120</i>	Low Loss Header with an Expansion Module, (1) High Temp Zone and (2) Low Temp Zones
<i>T-LL-EX-0130</i>	Low Loss Header with an Expansion Module, (1) High Temp Zone and (3) Low Temp Zones
<i>T-LL-EX-0210</i>	Low Loss Header with an Expansion Module, (2) High Temp Zones and (1) Low Temp Zone
<i>T-LL-EX-0220</i>	Low Loss Header with an Expansion Module, (2) High Temp Zones and (2) Low Temp Zones
<i>T-LL-EX-0310</i>	Low Loss Header with an Expansion Module, (3) High Temp Zones and (1) Low Temp Zone

*** Note:**

The following parts lists and application drawings are general samplings. Each panel configuration dictates the required components, including pump type. See the Technical Data section of the manual for specific information on each part in your particular variation of the Tamas Low Loss Header Panel.

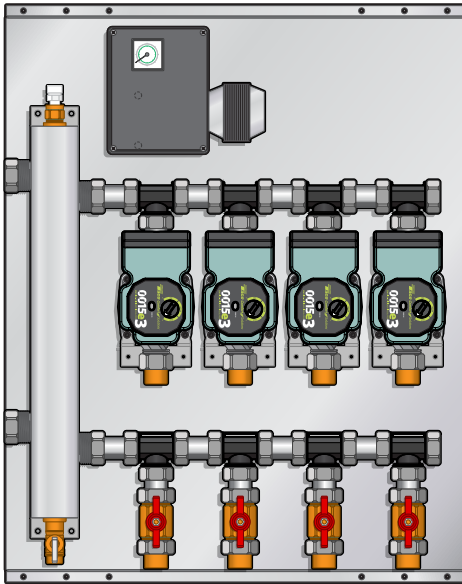

Low Loss Header Panel
T-LL-00-1400 Model Shown

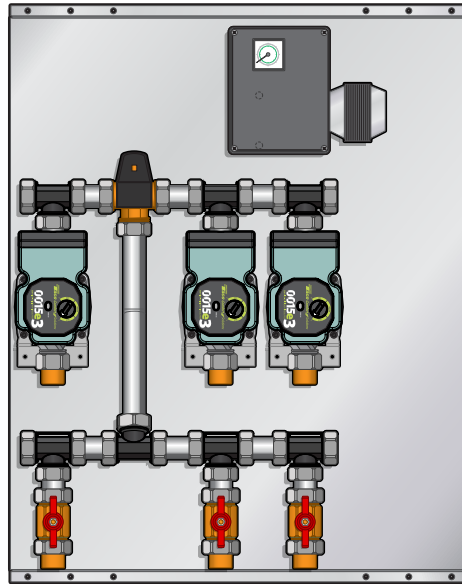

Low Loss Header Expansion Panel
T-LL-EX-0120 Model Shown

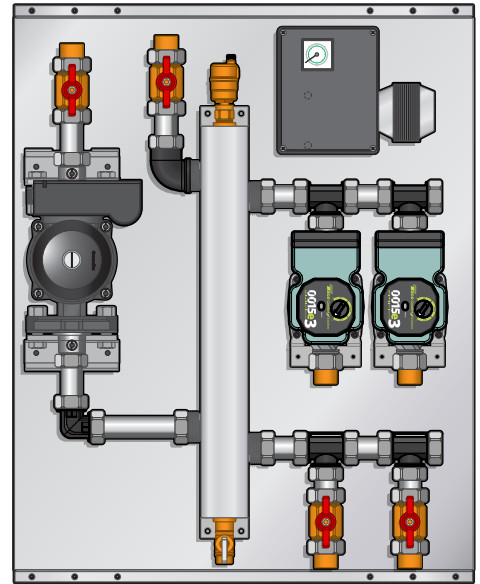

Low Loss Header Boiler Panel
T-LL-BD-2110 Model Shown

Description

When used in conjunction with boilers, the low-loss header acts as hydraulic break, decoupling boiler and system circuits from each other. The low-loss header increases operational efficiency. In addition, the low-loss header helps eliminate debris from the heating system. The low loss header panel is configured with expansion ports designed to accept input signals from future auxiliary panel. The panel is designed to hydronically isolate the primary boiler loop from the secondary zone loop.

Optional secondary injection mixing components, as well as low and high temperature zones can be added to the system. This enables the panel to accommodate DHW priority or fan coil applications. The panel can support a maximum of 5 pumps, including the DHW priority pump.

Installation

Prior to mounting the panel, ensure the wall is capable of supporting the weight of the panel. Ensure that an 115V receptacle is within reach of the 5-foot cord and plug.

Main Features

- Pre-designed and assembled
- Function & pressure tested
- Packaged, compact design
- Certified to CSA C22.2 No. 14-95
- Conforms to UL Standard 598A

Technical Data

- Flow Range: 0-17 US GPM
- Head Range: 0-19 Feet
- Motors: 2 Pole, Single Phase
- Max. Operating Temperature: 93°C/200°F
- Max. Ambient Temperature: 49°C/120°F
- Max. Operating Pressure: 10 Bar/145 PSI

Low Loss Header Panel Components

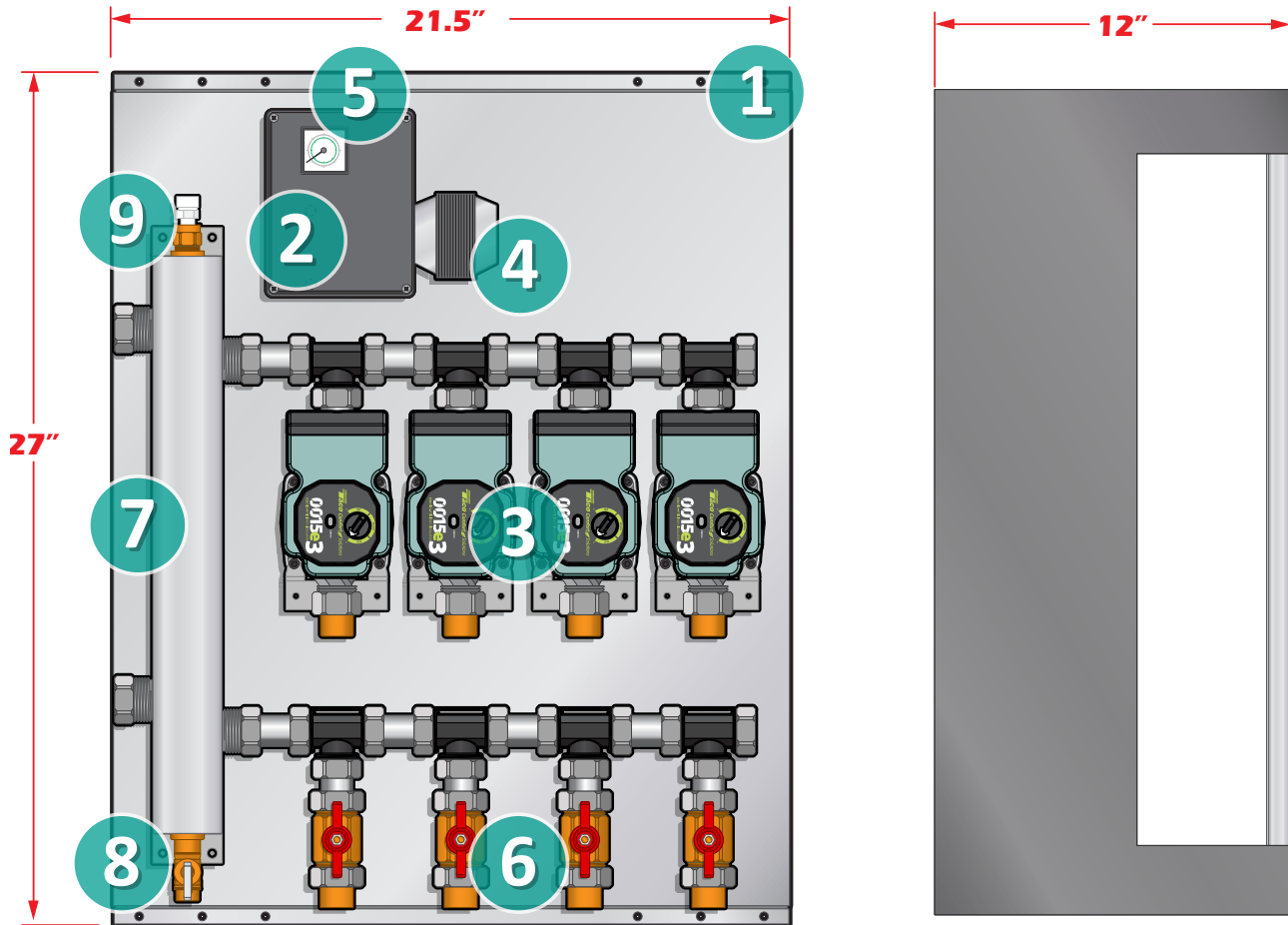

Components

1	22" x 26" Galvanized Backpan	6	Tamas Ball Valves
2	Tamas Control Box with 5' Power Cable	7	Stainless Steel Low Loss Header
3	Zone Pumps 0015e3	8	Hose Bib Hook-Up
4	24V AC Transformer with Internal Fuse	9	Manual Air Vent
5	Temperature Gauge		

Low Loss Header Expansion Panel Components

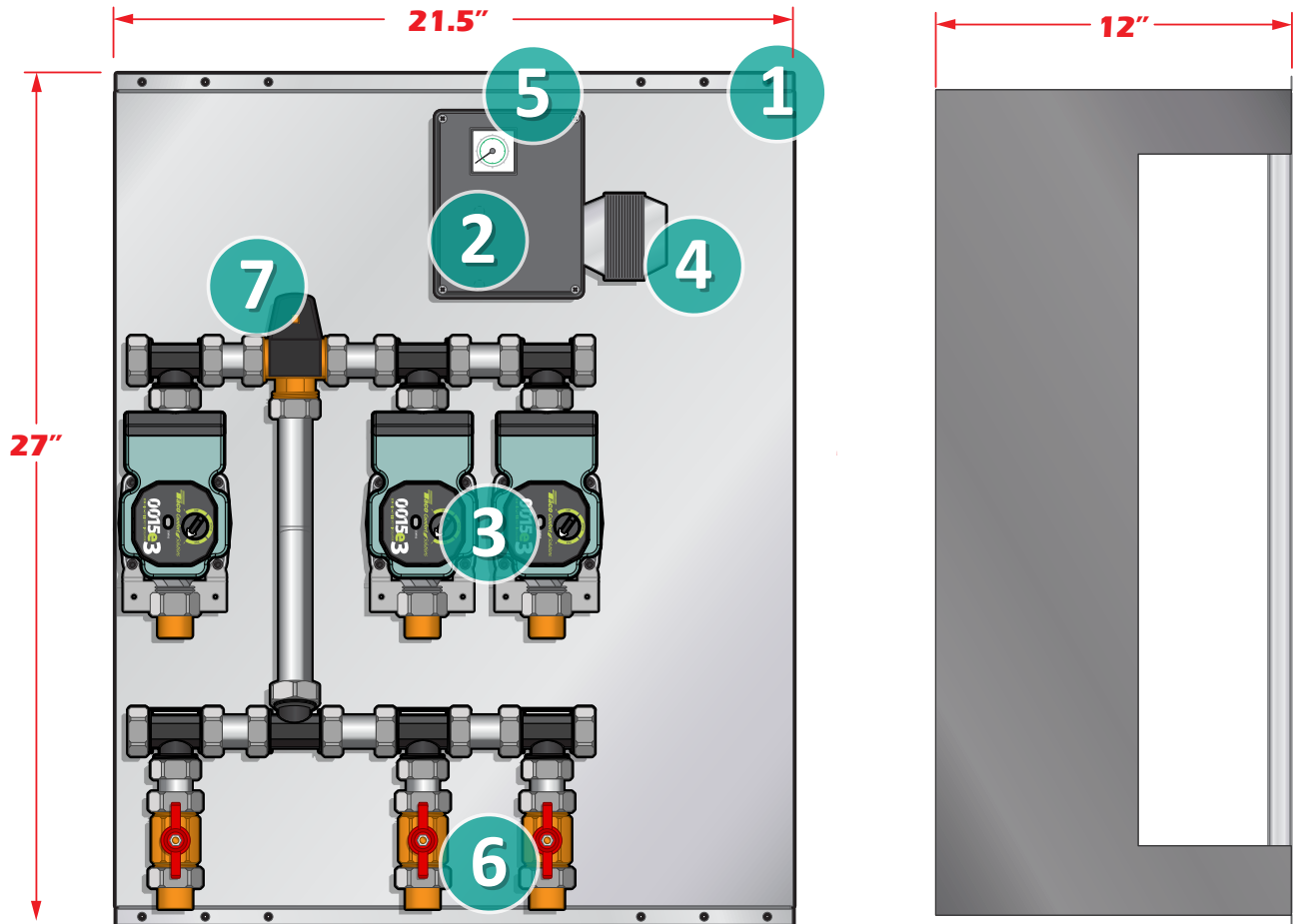

Components

1	22" x 26" Galvanized Backpan	5	Temperature Gauge
2	Tamas Control Box with 5' Power Cable	6	Tamas Ball Valves
3	Zone Pumps 0015e3	7	Thermostatic Mixing Valve
4	24V AC Transformer with Internal Fuse		

Low Loss Header Boiler Panel Components

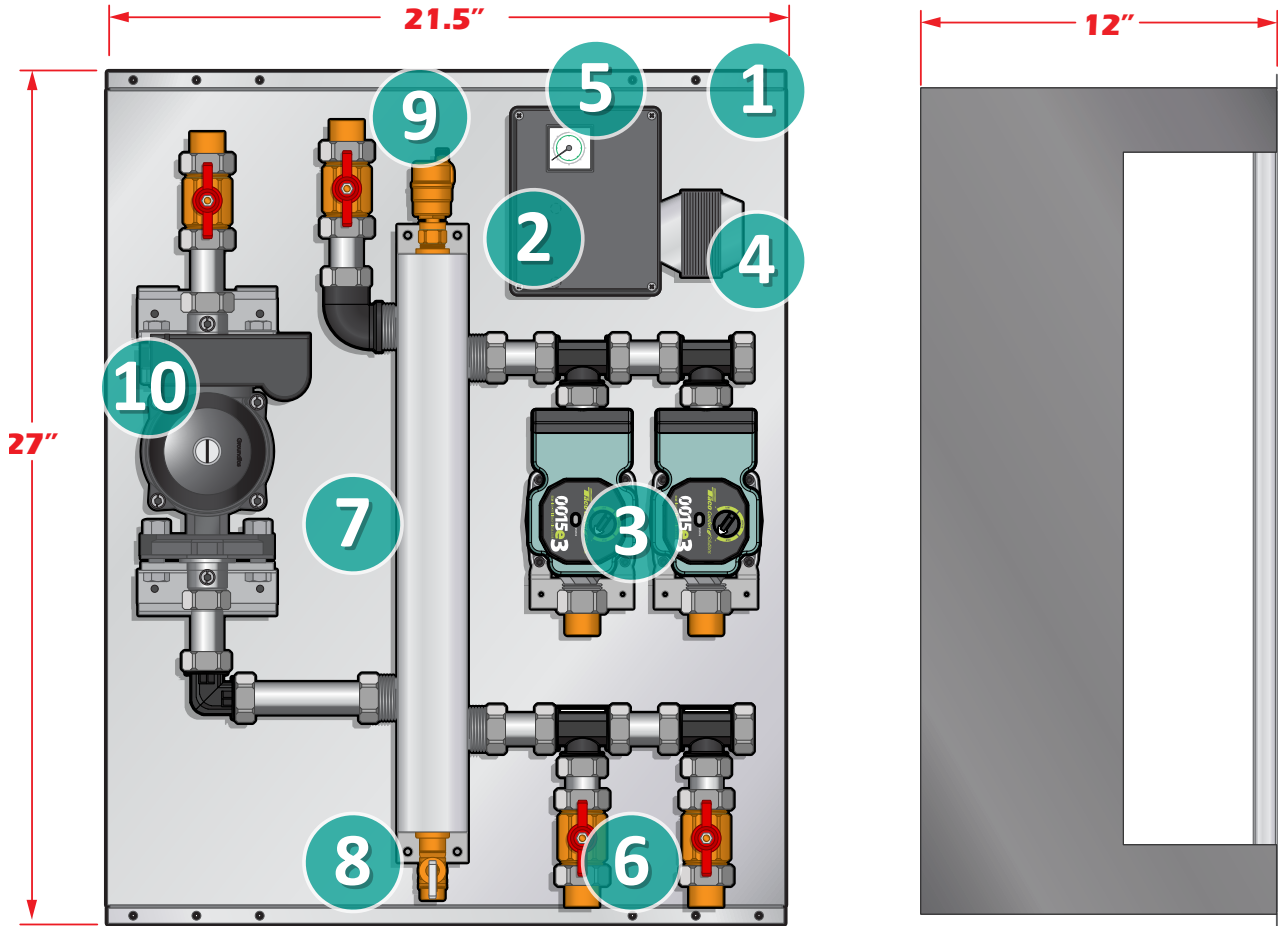

Components

1	22" x 26" Galvanized Backpan	6	Tamas Ball Valves
2	Tamas Control Box with 5' Power Cable	7	Stainless Steel Low Loss Header
3	Zone Pumps 0015e3	8	Hose Bib Hook-Up
4	24V AC Transformer with Internal Fuse	9	Air Vent
5	Temperature Gauge	10	Boiler Pump 0015e3 / UPS 26-99

Operation

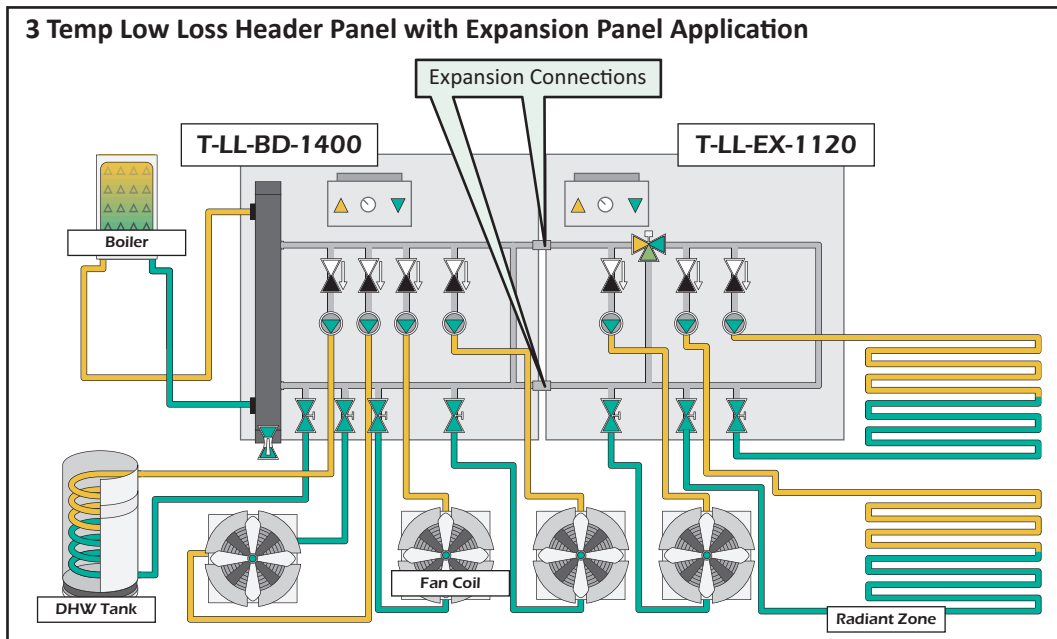

Operation of the Primary

When a Low Loss Header Panel is connected to a boiler system, the panel regulates the water distribution quantity to accommodate demand. If the room or floor temperature falls below the user's designated setting on a thermostat, for example (sold separately), the panel initiates a signal which has the control start the boiler pump and zone pumps. When the room temperature is satisfied, the thermostat or aquastat disconnects the heat source and pump.

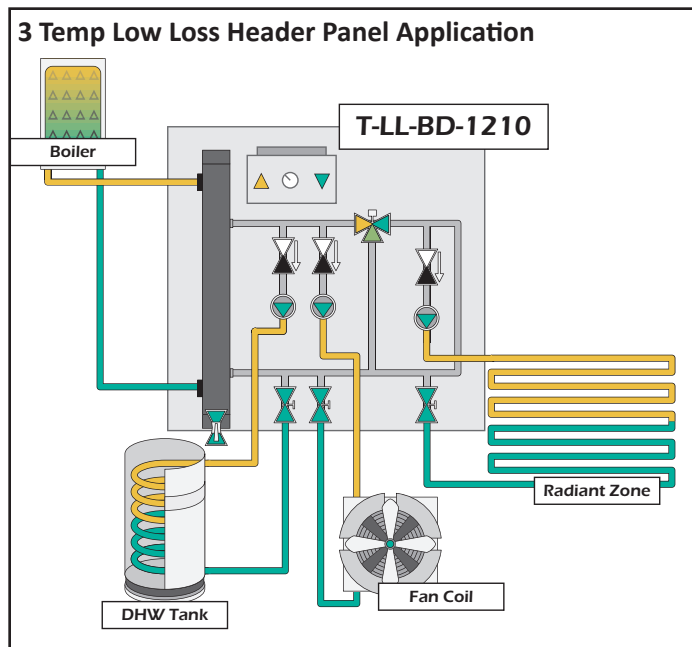

Operation of the Domestic Hot Water (DHW)

When there is a Domestic Hot Water application, and an aquastat demand is signaled, the panel disconnects the active zone pumps and sends a message to the boiler to raise the internal boiler water temperature. This water is heated and distributed as domestic hot water, when the domestic hot water demand is satisfied; the system disconnects the high temperature output and reverts to the preset zone temperatures that were previously active. This method of providing precedence to the domestic hot water requirements before the space heating load of a building is known as domestic hot water priority.

Pump Circulator Taco 0015e3 (3 Speed Pump)

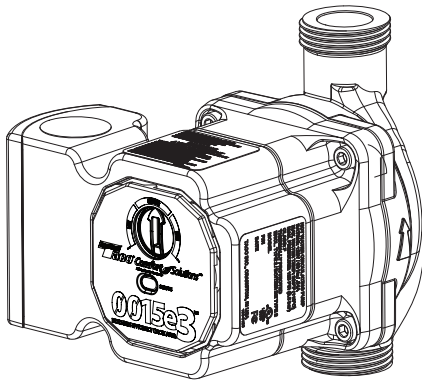
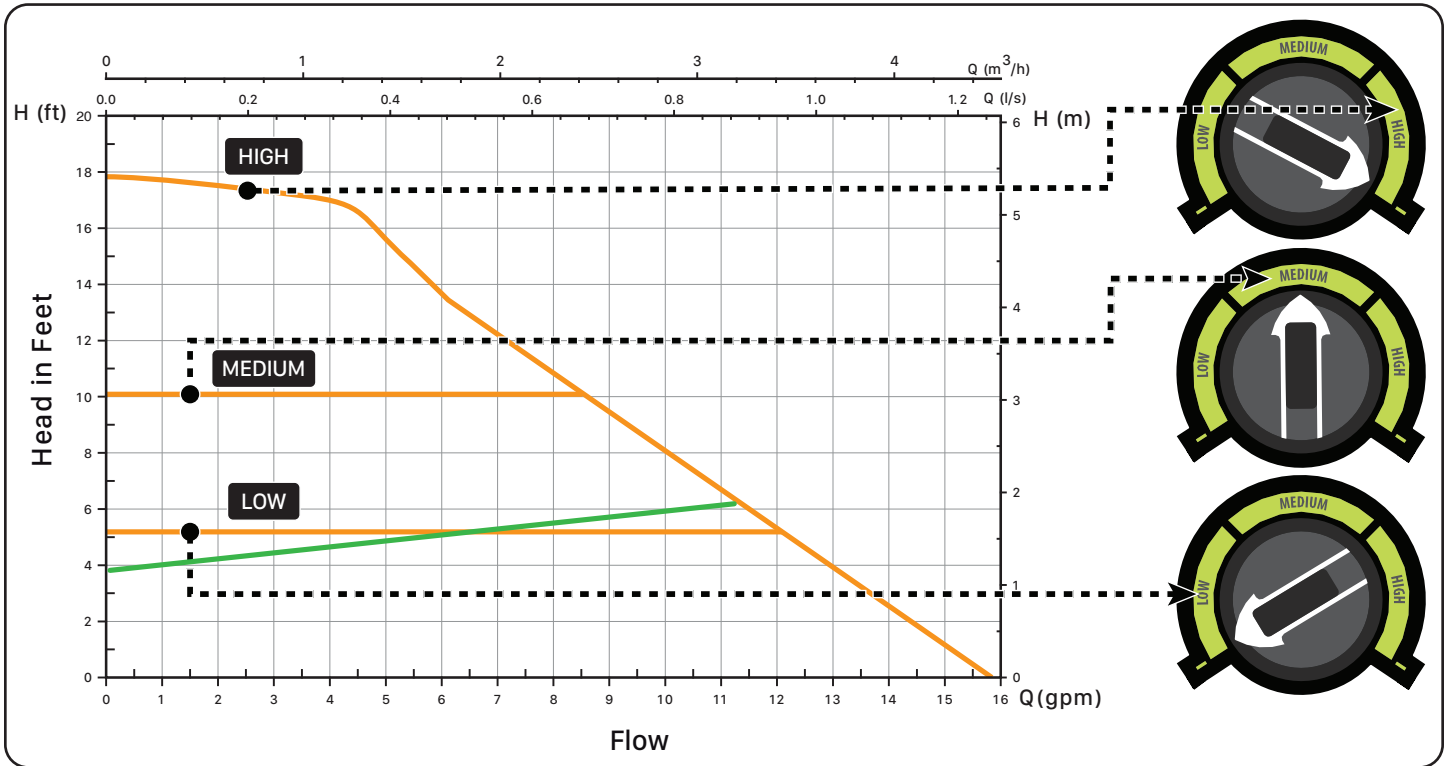

- Flow Range: 0-16 GPM
- Head Range (ft): 0-18'
- Max. Water Temp.: 230°F (110°C)
- Min. Water Temp.: 36°F (2°C)
- Voltage: 120V, 60 Hz Single phase
- Max. Operating Power: 44W
- Max. AMP Rating: 0.54

UPS 26-99 Pump

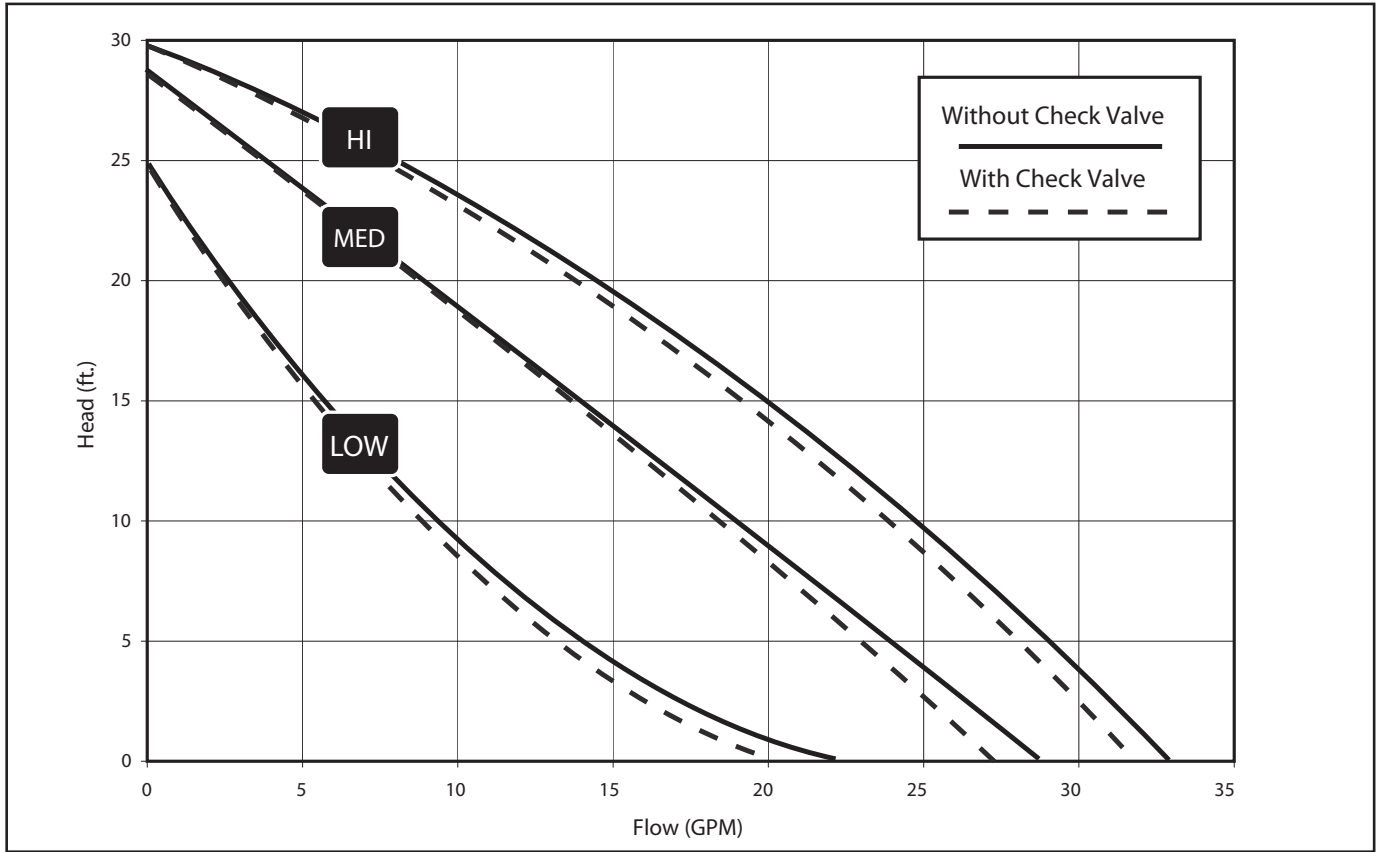

Flow range: 0 - 34 U.S. GPM
 Head range: 0 - 30 FEET
 Motors: 2 Pole, Single Phase
 Maximum fluid temperature: 230°F (110°C)
 Min. fluid temperature: 36°F (2°C)
 Maximum working pressure: 145 PSI

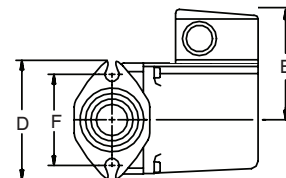
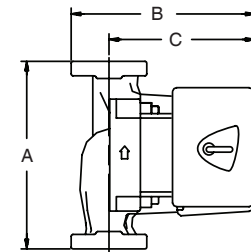

MODEL	VOLTS	AMPS	WATTS	HP	CAPACITOR
115V	Spd. 3	1.8	197	1/6	20mF/180V
	Spd. 2	1.5	179	1/6	20mF/180V
	Spd. 1	1.3	150	1/6	20mF/180V

Model Type	A	B	C	D	E	F	Connection Type and Size	Approximate Shipping Wt. (lbs)
UPS26-99FC/BFC	6 1/2	6	4 7/8	3 1/2	3 7/16	3 5/32	GF 15/26 Flange - (2) 1/2" Dia. Bolt Holes	10.3

Tamas Low Loss Header

Delta T	Max Flow Rate	BTU Load
20	24.2GPM	242000
25	24.2GPM	280000
30	24.2GPM	365000
35	24.2GPM	420000
40	24.2GPM	475000

Dimensions

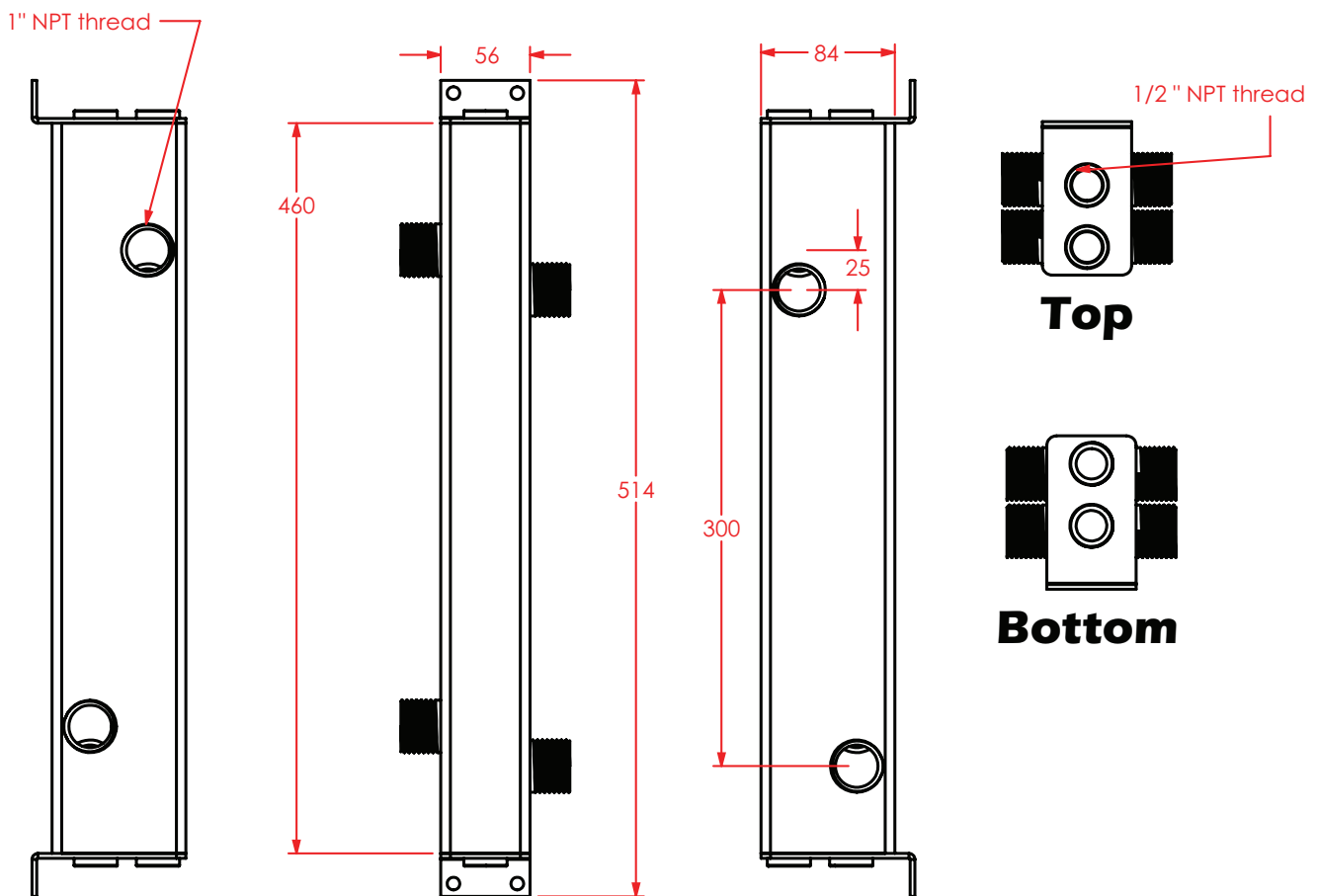

Wiring

All electrical wiring to the panel (including grounding) must conform to local electrical codes and/or National Electrical Code, ANS/NFPA No. 70-latest edition, or the Canadian Electrical Code, C22.1- Part 1.

Connections Boiler Panel – Boiler

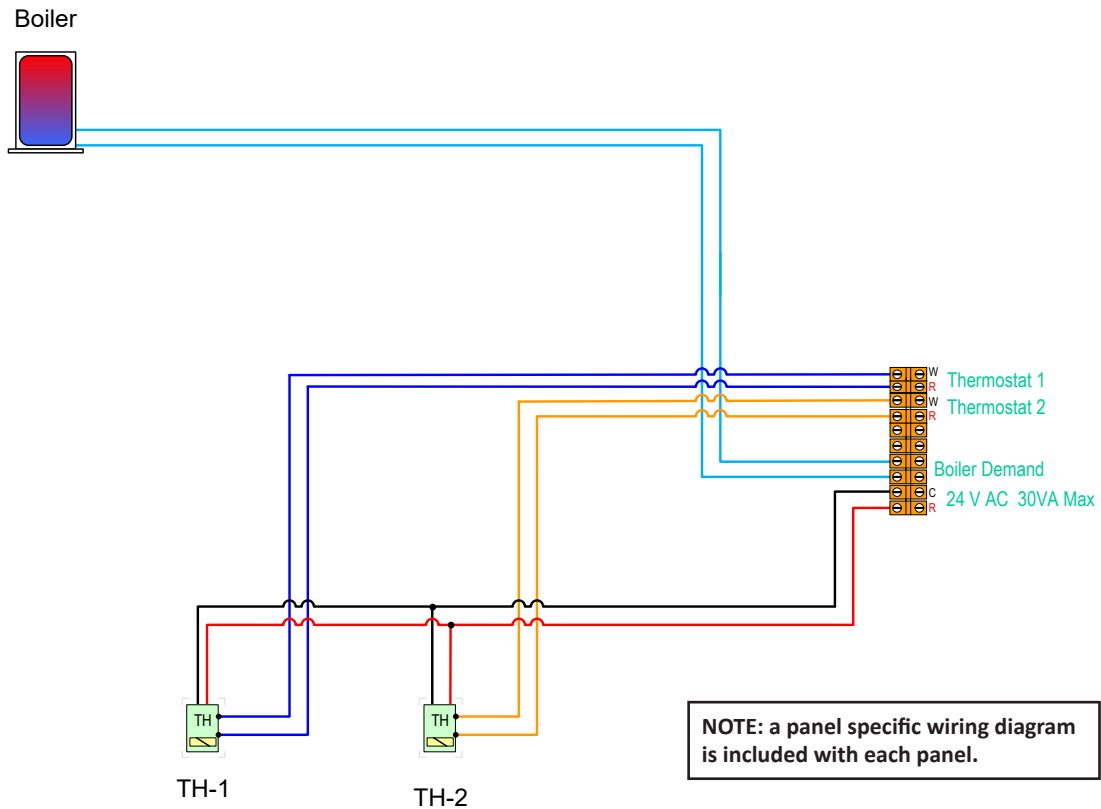

LOW Temperature Zones 1-2

Thermostat Connections

Connect the thermostat for a space heating zone to the terminal block on the Tamas Panel. Do not supply 24V power to the thermostat circuits or attempt to supply 24V AC for any other application.

For the thermostats that require continuous 24V AC power source, connect the thermostat power input to the 24V AC terminal on the Tamas Panel.

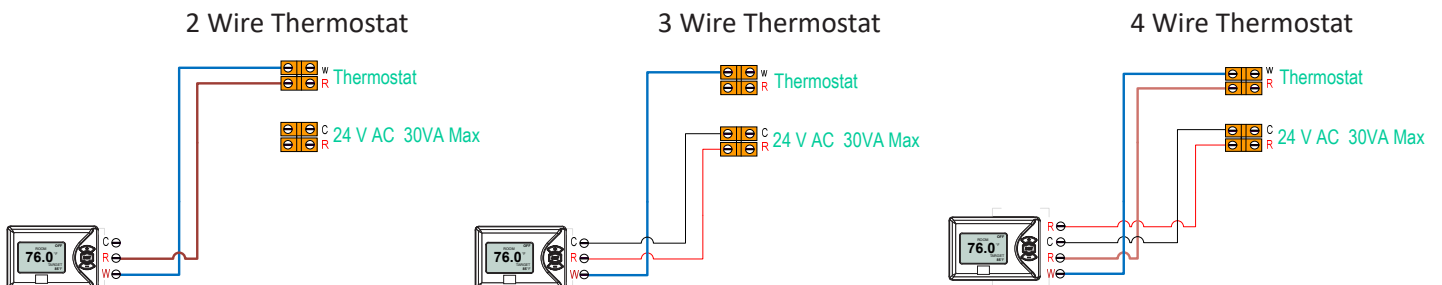

System Filling Procedure

1. Disconnect power from the Tamas Hydronic panel
2. Close all isolation valves to the zones
3. Begin filling the panel through the provided hose bib connection on the panel
4. Open the supply isolation valve on the panel for the first zone
5. Begin filling the system
6. Slowly open the Purging Valve (field supplied) on the return side of the zone line to let the air out of the system
7. Once the air has been eliminated from the zone, close the air purging valve
8. Finally close all the valves to isolate the zone from the panel before moving on to the next zone.
9. Repeat this procedure based on the amount of zones on the board
10. Once all the zones have been purged, you can open all the isolation valves

IMPORTANT This procedure applies to filling the system one zone at a time.

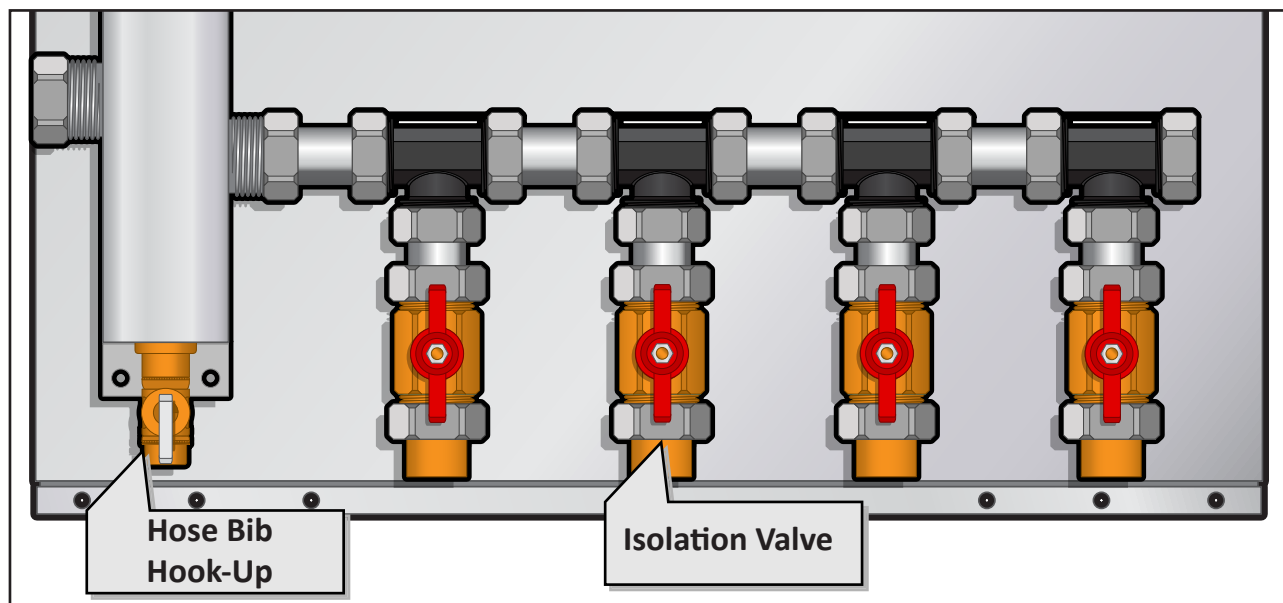



Limited Warranty

Tamas Hydronic Systems Inc. warrants each of its products to be free from defects in workmanship and materials under normal use and service for a period of 24 months from date of purchase from a Tamas Hydronic Systems inc. authorized Dealer.

If the product proves to be defective within the applicable warranty period, Tamas Hydronic Systems inc. on its sole discretion will repair or replace said product. Replacement product may be new or refurbished of equivalent or better specifications, relative to the defective product. Replacement product need not be of identical design or model. Any repair or replacement product pursuant to this warranty shall be warranted for not less than 90 days from date of such repair, irrespective of any earlier expiration of original warranty period. When Tamas Hydronic Systems Inc. Provides replacement, the defective product becomes the property of Tamas Hydronic Systems Inc.

Warranty Service, within the applicable warranty period, may be obtained by contacting your nearest Tamas Hydronics Systems inc. office via the original Authorized Agent and requesting a Return Material Authorization Number (RMA #). Proof of purchase in the form a dated invoice/receipt must be provided to expedite the issuance of a Factory RMA.

After an RMA number has been issued, the defective product must be packaged securely in the original or other suitable shipping package to ensure that it will not be damaged in transit. The RMA number must be visible on the outside of the package and a copy included inside the package. The package must be mailed or otherwise shipped back to Tamas Hydronic Systems Inc. with all costs of mailing/shipping/insurance prepaid by the warranty claimant.

Any package/s returned to Tamas Hydronic Systems Inc. without an approved and visible RMA number will be rejected and shipped back to purchaser at purchaser's expense. Tamas Hydronic Systems Inc. Reserves the right, if deemed necessary, to charge a reasonable levy for costs incurred, additional to mailing or shipping costs.

Limitation of Warranties.

If the Tamas Hydronic Systems Inc. product does not operate as warranted above the purchasers sole remedy shall be, at Tamas Hydronic Systems Inc.' s option, repair or replacement. The foregoing warranties and remedies are exclusive and in lieu of all other warranties, expressed or implied, either in fact or by operation of law, statutory or otherwise, including warranties of merchantability and fitness for a particular purpose/application. Tamas Hydronic Systems Inc. neither assumes nor authorizes any other person to assume for it any other liability in connection with the sale, installation maintenance or use of Tamas Hydronic Systems Inc. products.

Tamas Hydronic Systems Inc. shall not be liable under this warranty; if its testing and examination discloses that the alleged defect in the product does not exist or was caused by the purchasers or third persons misuse, neglect, improper installation or testing, unauthorized attempts to repair or any other cause beyond the range of intended use, or by accident, fire, lightning or other hazard.

Limitation of Liability.

In no event will Tamas Hydronic Systems Inc. be liable for any damages, including loss of data, loss of profits, costs of cover or other incidental, consequential or indirect damages arising out of the installation, maintenance, commissioning, performance, failure or interruption of a Tamas Hydronic Systems Inc. product, however caused and on any theory of liability. This limitation will apply even if Tamas Hydronic Systems Inc. has been advised of the possibility of such damage.

Local Law.

This limited warranty statement gives the purchaser specific legal rights. The purchaser may also have other rights which vary from state to state in the United States, from Province to Province in Canada and from Country to Country elsewhere in the world.

To the extent this Limited Warranty Statement is inconsistent with local law, this statement shall be deemed modified to be consistent with such local law. Under such local law, certain disclaimers and limitations of this statement may not apply to the purchaser. For example, some states in the United States, as well as some governments outside the United States (including Canadian Provinces), may:

Preclude the disclaimers and limitations in this statement from limiting the statutory rights of a consumer (e.g. United Kingdom);

Otherwise restrict the ability of a manufacturer to enforce such disclaimers or limitations; or

Grant the purchaser additional warranty rights which the manufacturer cannot disclaim, or not allow limitations on the duration of implied warranties.

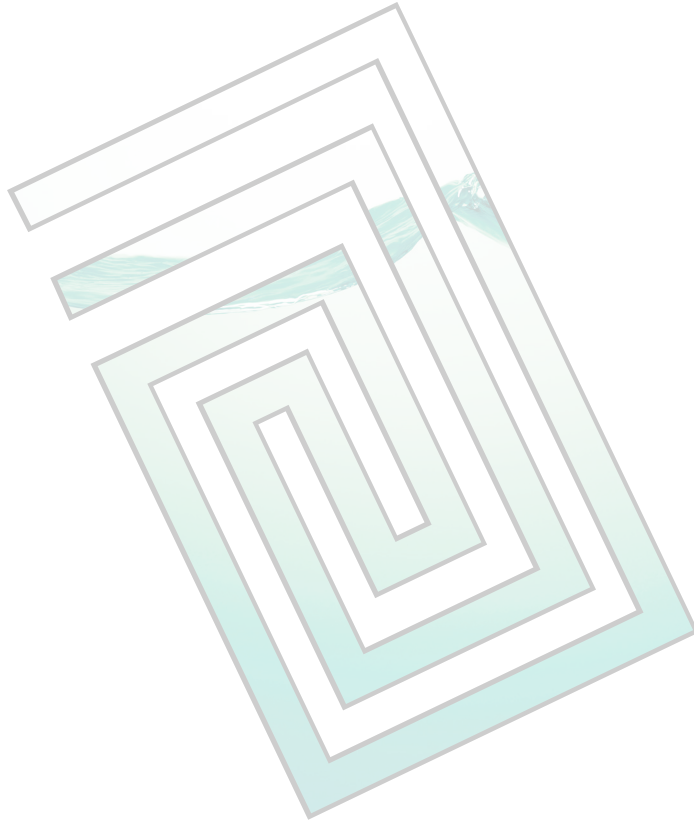

Custom, Reliable Hydronic Systems

Tamas Hydronic Systems Inc.
4516 112 Avenue SE
Calgary, Alberta T2C 2K2

Phone: 1 (403) 279 0020
Fax: 1 (403) 279 0747
info@tamashydronic.com



/TamasHydronicSystems



/TamasHydronic



/company/tamas-hydronic-systems