

High/Low Combination Series

Installation and Commissioning Guide



Introduction..... 3

Components..... 4

Operation..... 5

Technical Data..... 6-7

Wiring..... 8

Commissioning..... 9

Modular Expansion Panels..... 10

Warranty..... 11

This User Guide is Applicable to:

Low Temperature Panels

<i>T-HL-TP-0110</i>	High/Low Temp Panel with (1) TMV, (1) High Temp Zone and (1) Low Temp Zone
<i>T-HL-TP-0120</i>	High/Low Temp Panel with (1) TMV, (1) High Temp Zone and (2) Low Temp Zones
<i>T-HL-TP-0130</i>	High/Low Tem Panel with (1) TMV, (1) High Temp Zone and (3) Low Temp Zones
<i>T-HL-TP-0140</i>	High/Low Temp Panel with (1) TMV, (1) High Temp Zone and (4) Low Temp Zones
<i>T-HL-TP-0150</i>	High/Low Temp Panel with (1) TMV, (1) High Temp Zone and (5) Low Temp Zones
<i>T-HL-TP-0160</i>	High/Low Temp Panel with (1) TMV, (1) High Temp Zone and (6) Low Temp Zones
<i>T-HL-TP-0210</i>	High/Low Temp Panel with (1) TMV, (2) High Temp Zone and (1) Low Temp Zone
<i>T-HL-TP-0220</i>	High/Low Temp Panel with (1) TMV, (2) High Temp Zones and (2) Low Temp Zones
<i>T-HL-TP-0230</i>	High/Low Temp Panel with (1) TMV, (2) High Temp Zones and (3) Low Temp Zones
<i>T-HL-TP-0240</i>	High/Low Temp Panel with (1) TMV, (2) High Temp Zones and (4) Low Temp Zones
<i>T-HL-TP-0250</i>	High/Low Temp Panel with (1) TMV, (2) High Temp Zones and (5) Low Temp Zones
<i>T-HL-TP-0310</i>	High/Low Temp Panel with (1) TMV, (3) High Temp Zones and (1) Low Temp Zone
<i>T-HL-TP-0320</i>	High/Low Temp Panel with (1) TMV, (3) High Temp Zones and (2) Low Temp Zones
<i>T-HL-TP-0330</i>	High/Low Temp Panel with (1) TMV, (3) High Temp Zones and (3) Low Temp Zones
<i>T-HL-TP-0340</i>	High/Low Temp Panel with (1) TMV, (3) High Temp Zones and (4) Low Temp Zones
<i>T-HL-TP-0410</i>	High/Low Temp Panel with (1) TMV, (4) High Temp Zones and (1) Low Temp Zone
<i>T-HL-TP-0420</i>	High/Low Temp Panel with (1) TMV, (4) High Temp Zones and (2) Low Temp Zones
<i>T-HL-TP-0430</i>	High/Low Temp Panel with (1) TMV, (4) High Temp Zones and (3) Low Temp Zones
<i>T-HL-TP-0510</i>	High/Low Temp Panel with (1) TMV, (5) High Temp Zones and (1) Low Temp Zone
<i>T-HL-TP-0520</i>	High/Low Temp Panel with (1) TMV, (5) High Temp Zones and (2) Low Temp Zones
<i>T-HL-TP-0610</i>	High/Low Temp Panel with (1) TMV, (6) High Temp Zones and (1) Low Temp Zone

*** Note:**

The following parts lists and application drawings are general samplings. Each panel configuration dictates the required components, including pump type. See the Technical Data section of the manual for specific information on each part in your particular variation of the Tamas High/Low Combination Panel.

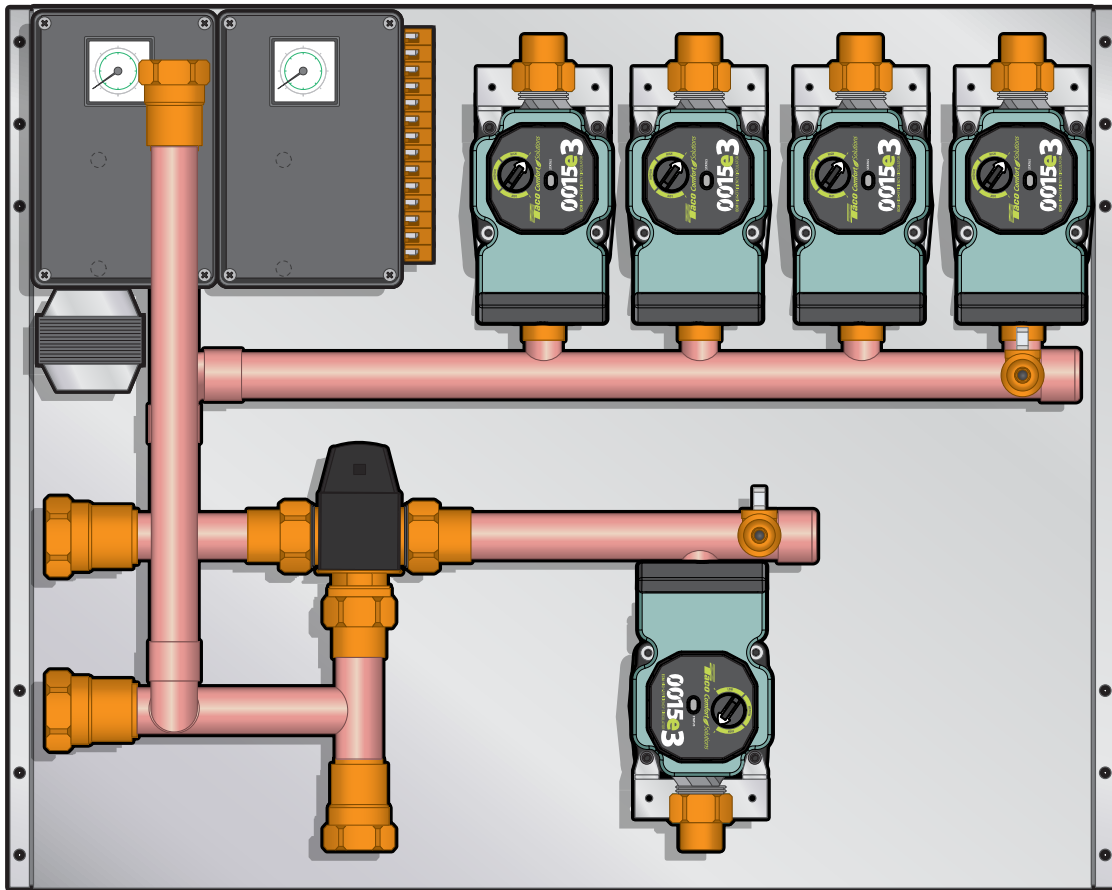

T-HL-TP-0410 Model Shown

Description

The Tamas High/Low Temperature Combination Panel is specifically designed to accommodate multiple temperature applications in the same system, up to a maximum of 7 zones. This versatile panel can also be used with a dedicated condensing boiler. The 3-speed pumps used will accommodate the flow requirements for most warm and hot water requirements. A DHW priority configuration is also an option for this panel.

With a compact design the panel allows for a great option for retrofit or new installs. With many configurations available the High/Low panel is one of the most versatile products offered.

Main Features

- Galvanized steel back plate and lockable galvanized steel cover
- Thermostatic mixing valve
- Plug and Play design
- ETL approved

Technical Data

- Flow Range: 0-17 US GPM
- Head Range: 0-19 Feet
- Motors: 2 Pole, Single Phase
- Maximum Fluid Temperature: 230 °F (110 °C)
- Minimum Fluid Temperature: 36 °F (2°C)

Components

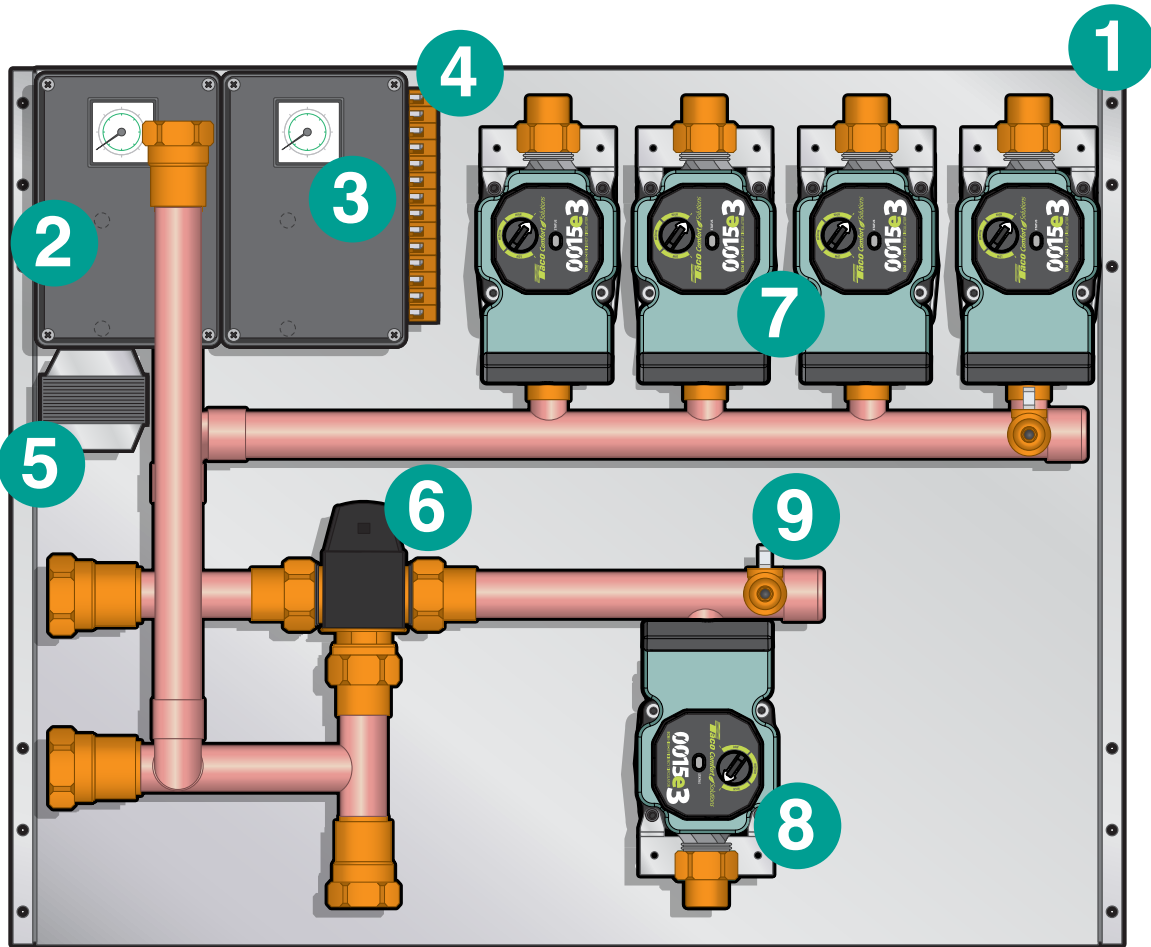

Components			
1	Galvanized Backpan	6	Thermostatic Mixing Valve
2	Tamas Control Box	7	High Temperature Zone Pumps Taco 0015e3
3	Tamas Temperature Gauge	8	Low Temperature Zone Pumps Taco 0015e3
4	Control Terminals	9	Fill/Drain Valve
5	Transformer		

Boiler Connection

When the Tamas High/Low Temperature Combination Panel T-HL-TP-0XXX is connected to a boiler system the panel regulates the water distribution and temperature to accommodate demand.

When the room or floor temperature falls below the user’s desired setting on a thermostat (sold separately), the panel initiates a signal to the boiler which will turn on the boiler pump(field supplied) and at the same time, turn on the high or low temperature pumps

When the room temperature is satisfied, the thermostat disconnects the demand to the Tamas Panel which will then end the boiler demand and turn off all pumps on the Tamas panel. (Depending on the boiler, the boiler pump will continue to run for a post purge on the boiler loop meanwhile the Tamas panel will be shut down.)

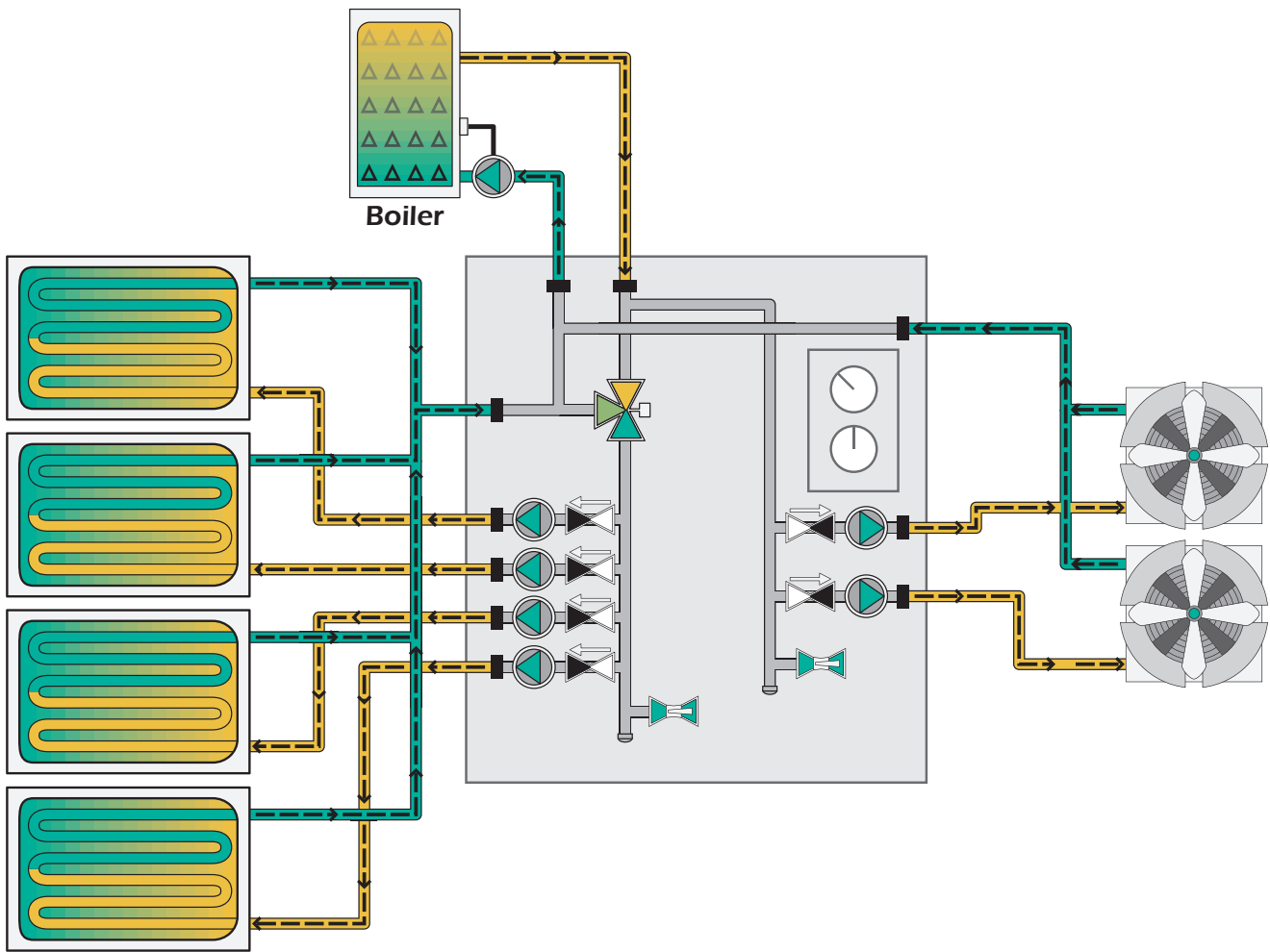

Pump Circulator Taco 0015e3 (3 Speed Pump)

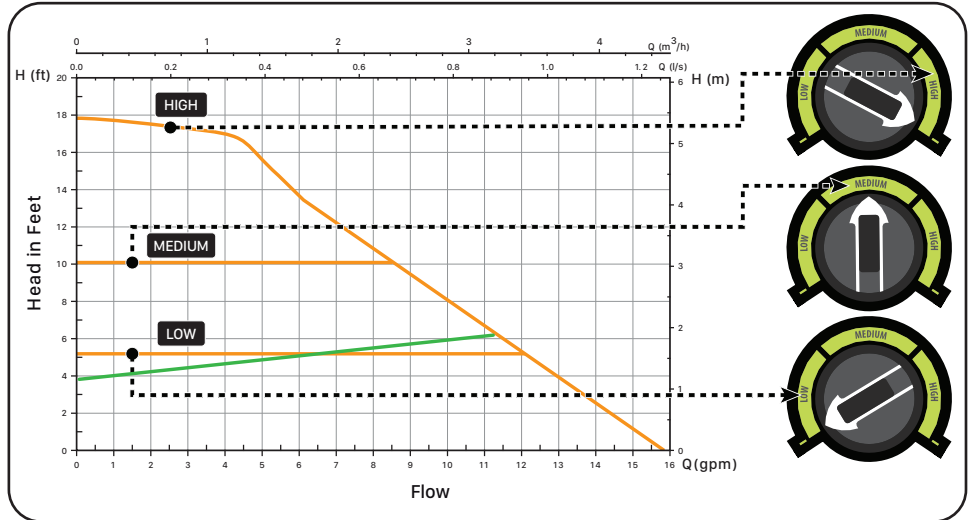
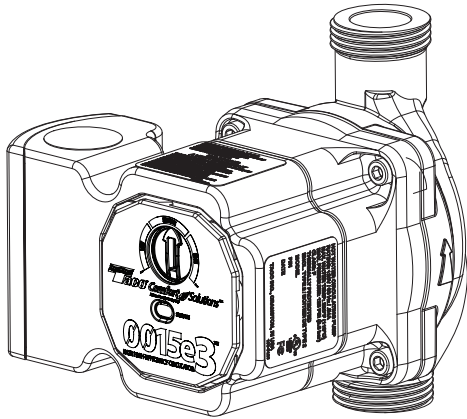

- Flow Range: 0-16 GPM
- Head Range (ft): 0-18'
- Max. Water Temp.: 230°F (110°C)
- Min. Water Temp.: 36°F (2°C)
- Voltage: 120V, 60 Hz Single phase
- Max. Operating Power: 44W
- Max. AMP Rating: 0.54

Dimensions

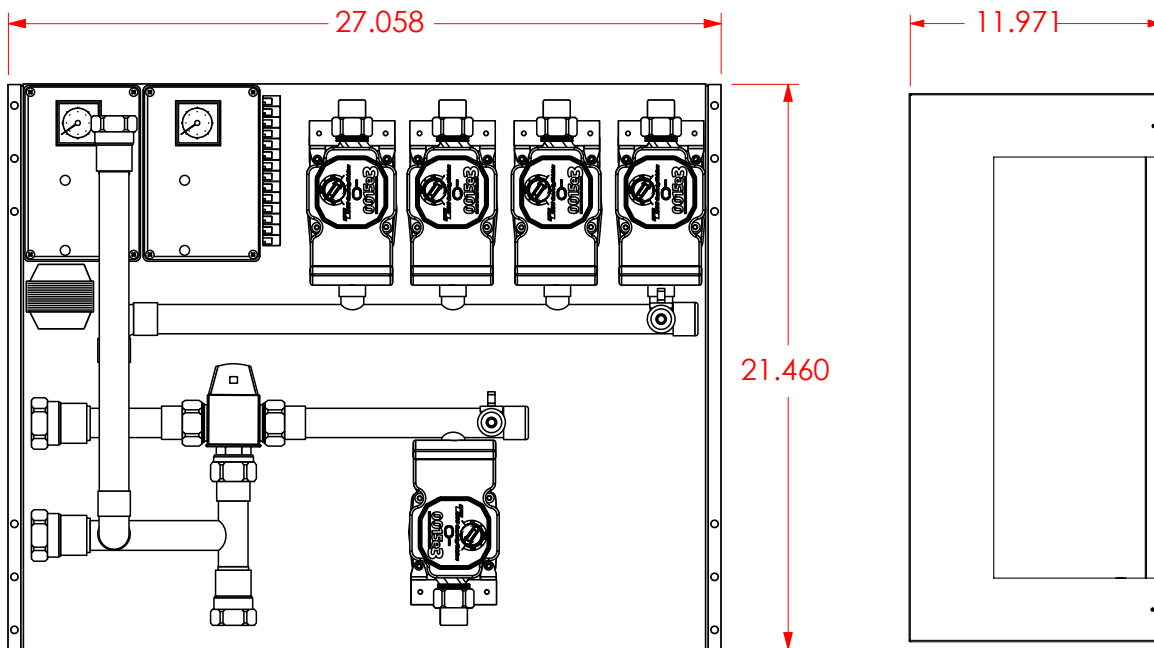

NOTE: Dimensions are in inches.

Thermostatic mixing valve

- Pressure class:** PN 10
- Working pressure:** 1.0 MPa
- Max. differential pressure:** Mixing: 0.3 MPa
- Media temperature:** max.: 100 °C
- Temperature stability:** ± 4 °C
- Connection:** Internal thread (Rp): EN 10226-1
External thread (G): ISO 228/1
External thread (R): EN 10226-1
- Compression fitting (CPF):** EN 1254-2
- Material:** Valve housing and other metal parts with fluid contact: Dezincification resistant brass, DZR
- Conformity:** PED97/23/EC, article 3.3

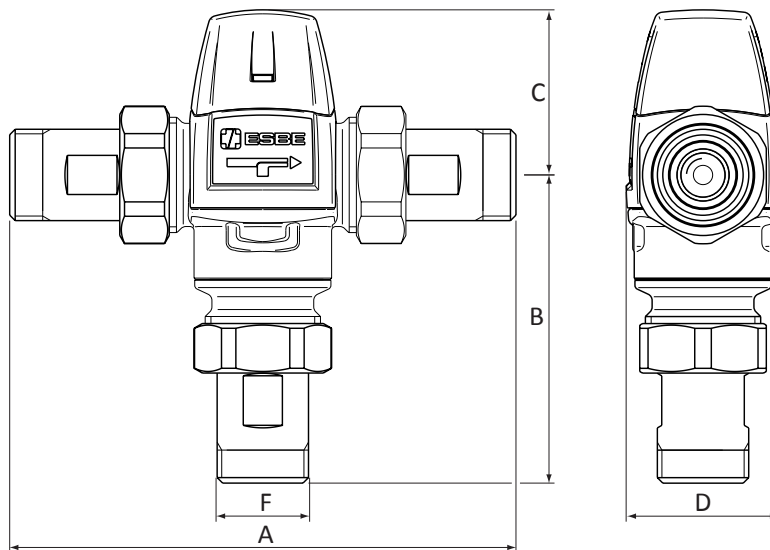
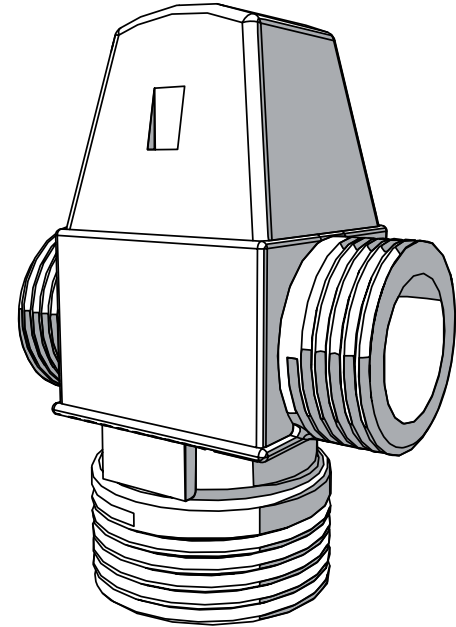

Reference	Temp. range	Kvs*	Connection F	Dimension				Note	Weight [kg]
				A	B	C	D		
VTA522	20 - 43°C	3.4	R 1"	164	102	60	56	2)	1.59

* Kvs-value in m³/h at a pressure drop of 1 bar. CPF = compression fitting
Note 2) Two check valves for both hot and cold water are included

Wiring

All electrical wiring to the Tamas panel (including grounding) must conform to local electrical codes and/or National Electrical Code, ANS/NFPA No. 70 - latest edition, or the Canadian Electrical Code, C22.1 – Part 1.

Boiler

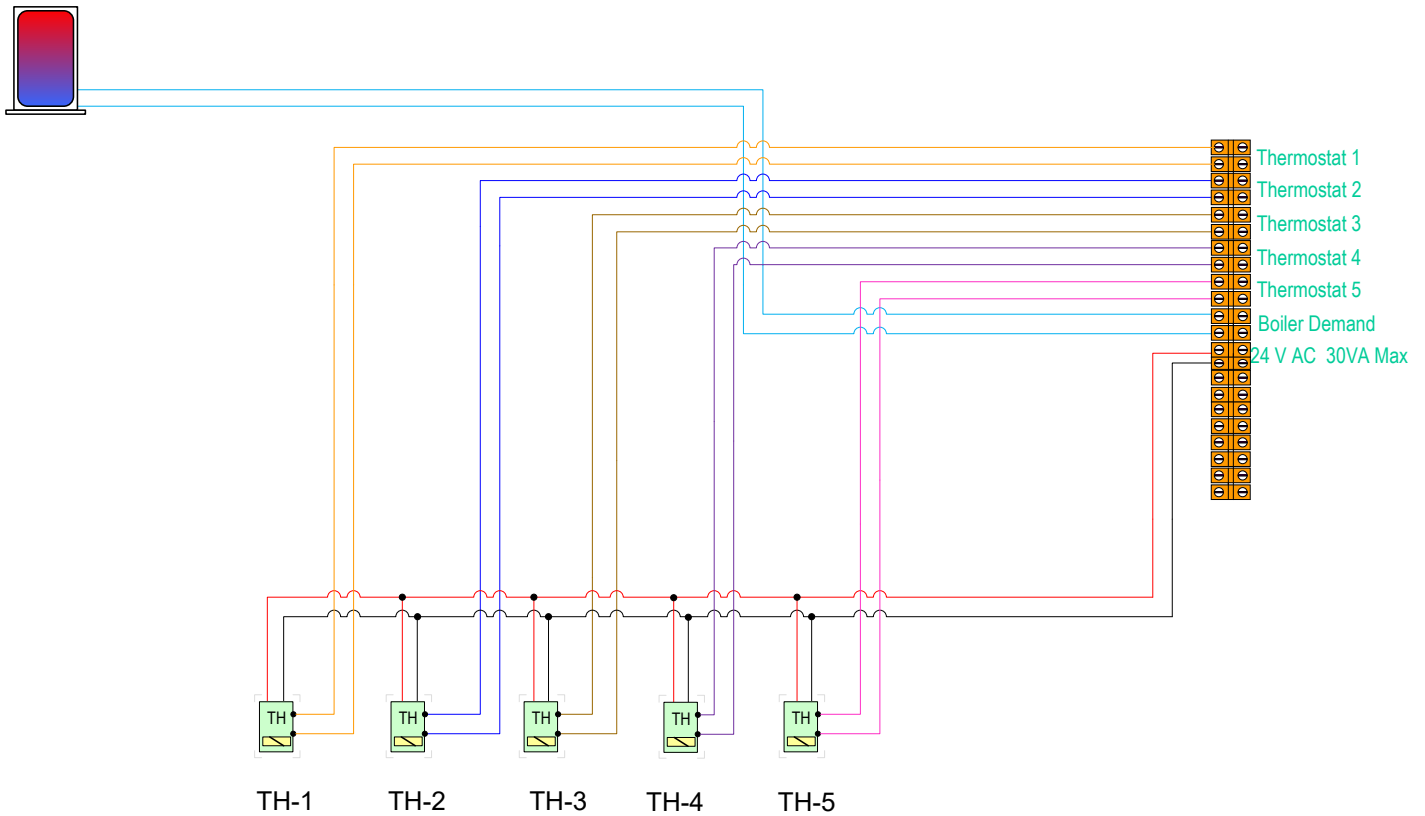

Thermostat 1-2

Connect the thermostat for a space heating zone to the terminal block on the Tamas Panel. Do not supply 24V power to the thermostat circuits or attempt to supply 24V AC for any other application.

For the thermostats that require continuous 24V AC power source, connect the thermostat power input to the 24V AC terminal on the Tamas Panel.

2 Wire Thermostat

3 Wire Thermostat

4 Wire Thermostat

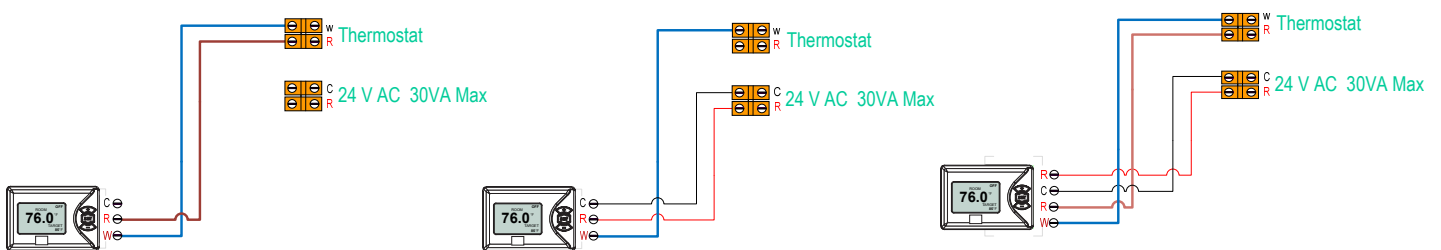

System Filling Procedure

1. Disconnect power from the Tamas Hydronic panel
2. Install recommended purging valve on return zone line.(field supplied see below drawing)
3. Close all isolation valves to the zones
4. Begin filling the panel through the provided hose bib connection on the panel
5. Open the return isolation valve on the panel
6. Begin filling the system
7. Slowly open the purging valve on the return side of the zone line to let the air out of the system
8. After the above procedure is done, close the air purging valve
9. Finally close all the valves to isolate the zone from the panel before moving on to the next zone.
10. Repeat this procedure based on the amount of zones on the board
11. Once all the zones have been purged, you can open all the isolation valves

IMPORTANT This procedure is applies to filling the system one zone at a time.

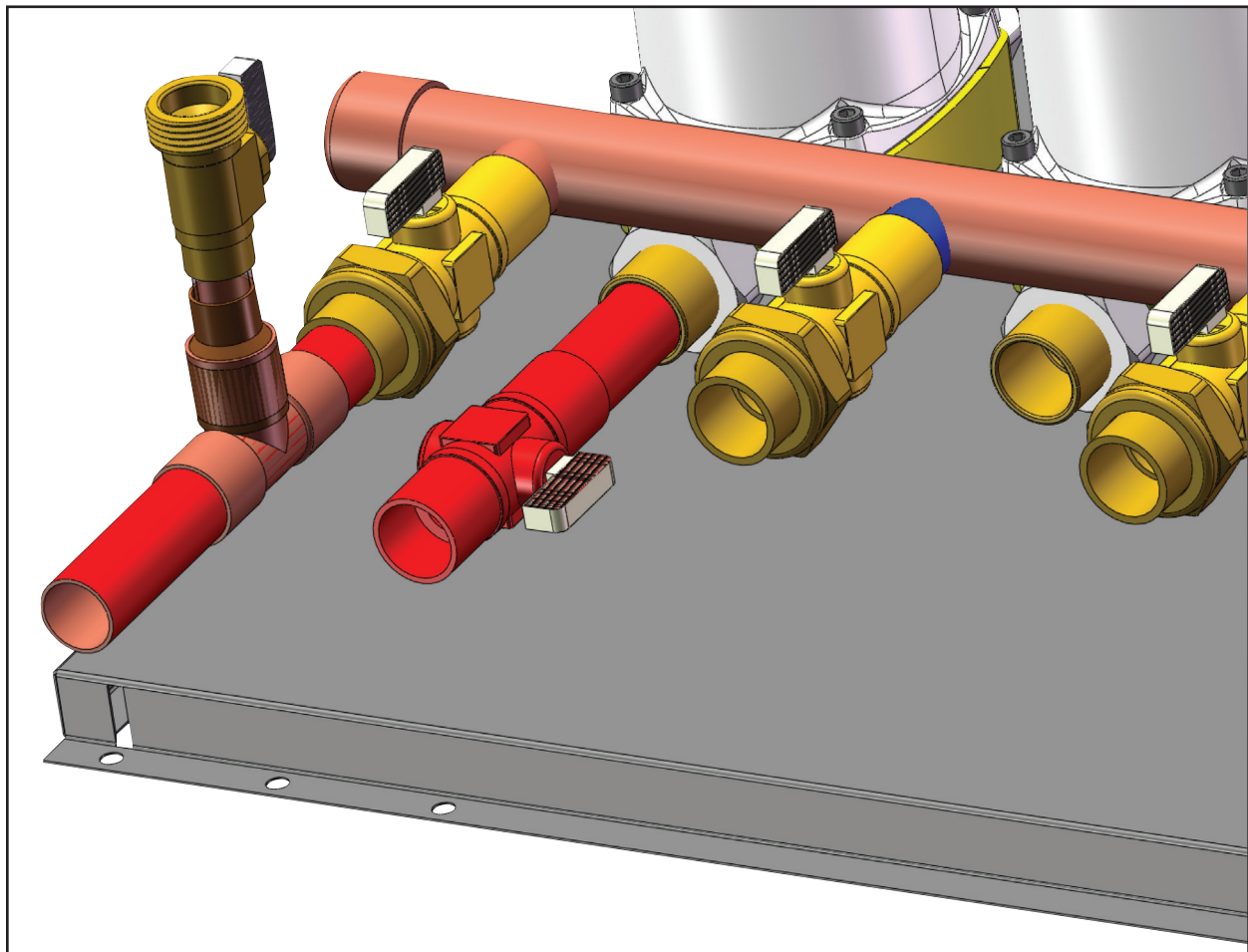



Tamas Hydronic Panels High/Low Combination Series Limited Warranty

Limited Warranty

Tamas Hydronic Systems Inc. warrants each of its products to be free from defects in workmanship and materials under normal use and service for a period of 24 months from date of purchase from a Tamas Hydronic Systems inc. authorized Dealer.

If the product proves to be defective within the applicable warranty period, Tamas Hydronic Systems inc. on its sole discretion will repair or replace said product. Replacement product may be new or refurbished of equivalent or better specifications, relative to the defective product. Replacement product need not be of identical design or model. Any repair or replacement product pursuant to this warranty shall be warranted for not less than 90 days from date of such repair, irrespective of any earlier expiration of original warranty period. When Tamas Hydronic Systems Inc. Provides replacement, the defective product becomes the property of Tamas Hydronic Systems Inc.

Warranty Service, within the applicable warranty period, may be obtained by contacting your nearest Tamas Hydronics Systems inc. office via the original Authorized Agent and requesting a Return Material Authorization Number (RMA #). Proof of purchase in the form a dated invoice/receipt must be provided to expedite the issuance of a Factory RMA.

After an RMA number has been issued, the defective product must be packaged securely in the original or other suitable shipping package to ensure that it will not be damaged in transit. The RMA number must be visible on the outside of the package and a copy included inside the package. The package must be mailed or otherwise shipped back to Tamas Hydronic Systems Inc. with all costs of mailing/shipping/insurance prepaid by the warranty claimant.

Any package/s returned to Tamas Hydronic Systems Inc. without an approved and visible RMA number will be rejected and shipped back to purchaser at purchaser's expense. Tamas Hydronic Systems Inc. Reserves the right, if deemed necessary, to charge a reasonable levy for costs incurred, additional to mailing or shipping costs.

Limitation of Warranties.

If the Tamas Hydronic Systems Inc. product does not operate as warranted above the purchasers sole remedy shall be, at Tamas Hydronic Systems Inc.' s option, repair or replacement. The foregoing warranties and remedies are exclusive and in lieu of all other warranties, expressed or implied, either in fact or by operation of law, statutory or otherwise, including warranties of merchantability and fitness for a particular purpose/application. Tamas Hydronic Systems Inc. neither assumes nor authorizes any other person to assume for it any other liability in connection with the sale, installation maintenance or use of Tamas Hydronic Systems Inc. products.

Tamas Hydronic Systems Inc. shall not be liable under this warranty; if its testing and examination discloses that the alleged defect in the product does not exist or was caused by the purchasers or third persons misuse, neglect, improper installation or testing, unauthorized attempts to repair or any other cause beyond the range of intended use, or by accident, fire, lightning or other hazard.

Limitation of Liability.

In no event will Tamas Hydronic Systems Inc. be liable for any damages, including loss of data, loss of profits, costs of cover or other incidental, consequential or indirect damages arising out of the installation, maintenance, commissioning, performance, failure or interruption of a Tamas Hydronic Systems Inc. product, however caused and on any theory of liability. This limitation will apply even if Tamas Hydronic Systems Inc. has been advised of the possibility of such damage.

Local Law.

This limited warranty statement gives the purchaser specific legal rights. The purchaser may also have other rights which vary from state to state in the United States, from Province to Province in Canada and from Country to Country elsewhere in the world.

To the extent this Limited Warranty Statement is inconsistent with local law, this statement shall be deemed modified to be consistent with such local law. Under such local law, certain disclaimers and limitations of this statement may not apply to the purchaser. For example, some states in the United States, as well as some governments outside the United States (including Canadian Provinces), may:

Preclude the disclaimers and limitations in this statement from limiting the statutory rights of a consumer (e.g. United Kingdom);

Otherwise restrict the ability of a manufacturer to enforce such disclaimers or limitations; or

Grant the purchaser additional warranty rights which the manufacturer cannot disclaim, or not allow limitations on the duration of implied warranties.

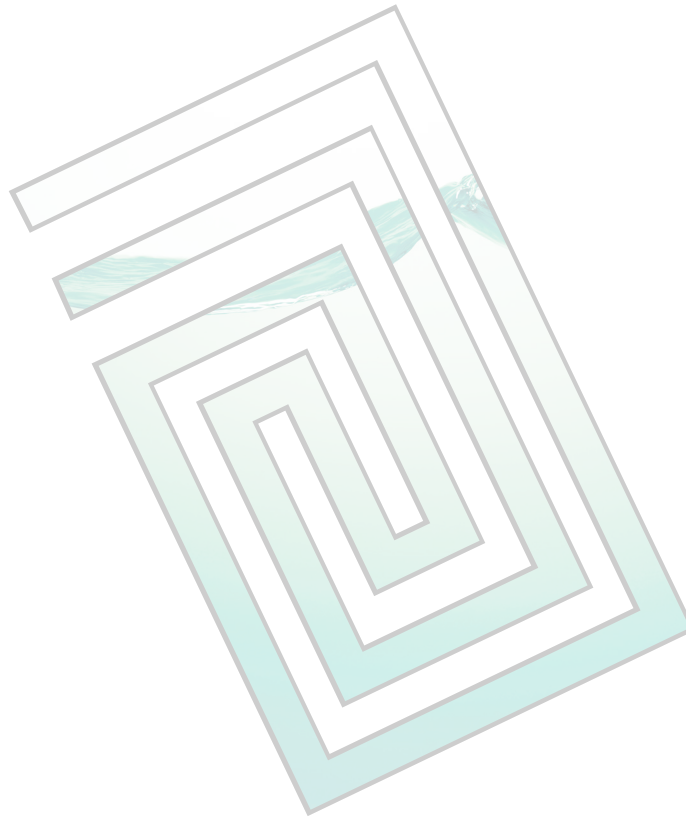

Custom, Reliable Hydronic Systems

Tamas Hydronic Systems Inc.
4516 112 Avenue SE
Calgary, Alberta T2C 2K2

Phone: 1 (403) 279 0020
Fax: 1 (403) 279 0747
info@tamashydronic.com



[/TamasHydronicSystems](#)



[/TamasHydronic](#)



[/company/tamas-hydronic-systems](#)