

NTI Trinity Boiler Series

Installation and Commissioning Guide



Tamas Hydronic Panels
NTI Trinity Boiler Series
Table of Contents

Introduction..... 3

Components..... 4

Operation..... 5

Technical Data..... 6-7

Wiring..... 8-9

Commissioning..... 10

Warranty..... 11

This User Guide is Applicable to:

NTI Trinity Boiler Panels

T-BO-ND-1220 NTI Trinity Boiler Panel with (2) UPS 15-58 Low Temperature Zone pumps, (2) UPS 15-58 High Temperature Zone pumps, and (1) UPS 15-58 Boiler Pump

*** Note:**

The following parts lists and application drawings are general samplings. Each panel configuration dictates the required components, including pump type. See the Technical Data section of the manual for specific information on each part in your particular variation of the Tamas NTI Trinity Boiler Panel.

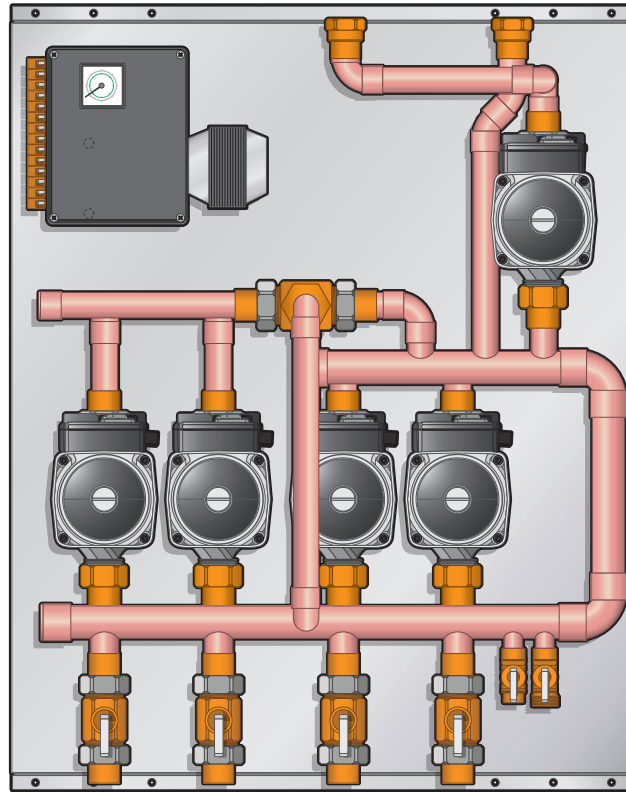

T-BO-ND-XXXX Model Shown

Description

The Tamas NTI Trinity Series Boiler Panel product line contains a series of expandable panels suited for a variety of applications and building sizes using the NTI Trinity Boiler Series.

Use

When a T-BO-NO-XXXX-N panel is connected to a NTI Trinity Boiler system, the panel regulates the water distribution quantity to accommodate demand.

Optional secondary injection mixing components, as well as low and high temperature zones can be added to the system.

The panel can accommodate up to four zones. For additional models, contact Tamas Hydronic Systems.

Main Features

- Hydraulic separation between the primary and the secondary
- Powder coated enclosure
- ETL approved
- Compatible connections: 1"
- **Technical Data**
- Max. Operating Temperature: 90°C/194°F
- Max. Ambient Temperature: 50°C/122°F
- Max. Operating Pressure: 10 Bar/145 PSI
- Power supply: 120V 15A

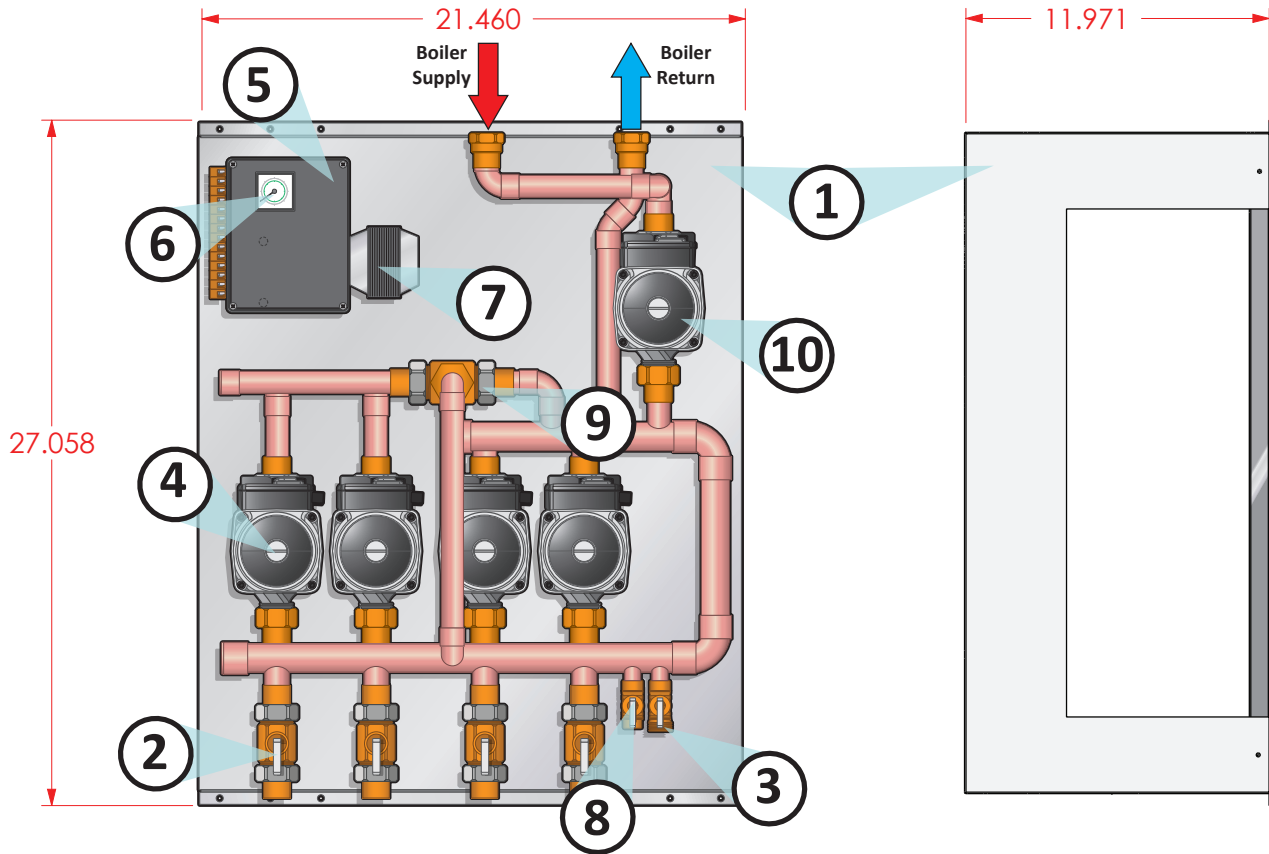

Components			
1	22" x 26" Galvanized Back Plate and Powder Coated Enclosure	6	Temperature Gauge
2	Ball Valves	7	Transformer
3	Hose Bib Hook-up 1/2"	8	Expansion Tank Hook-up 1/2"
4	Zone Pumps (UPS 15-58)	9	Thermostatic Mixing Valve
5	Tamas Control Box	10	Boiler Pump (UPS 15-58)

Operation

Heating

Different configurations are possible; one, two, three or four zones can be supplied.

If the zone temperature falls below the users designated setting on a thermostat (sold separately), for example, the panel initiates a signal back to the boiler and turns on the zone pumps.

When the zone temperature is satisfied, the thermostat or aquastat turns off the boiler and the zone pump.

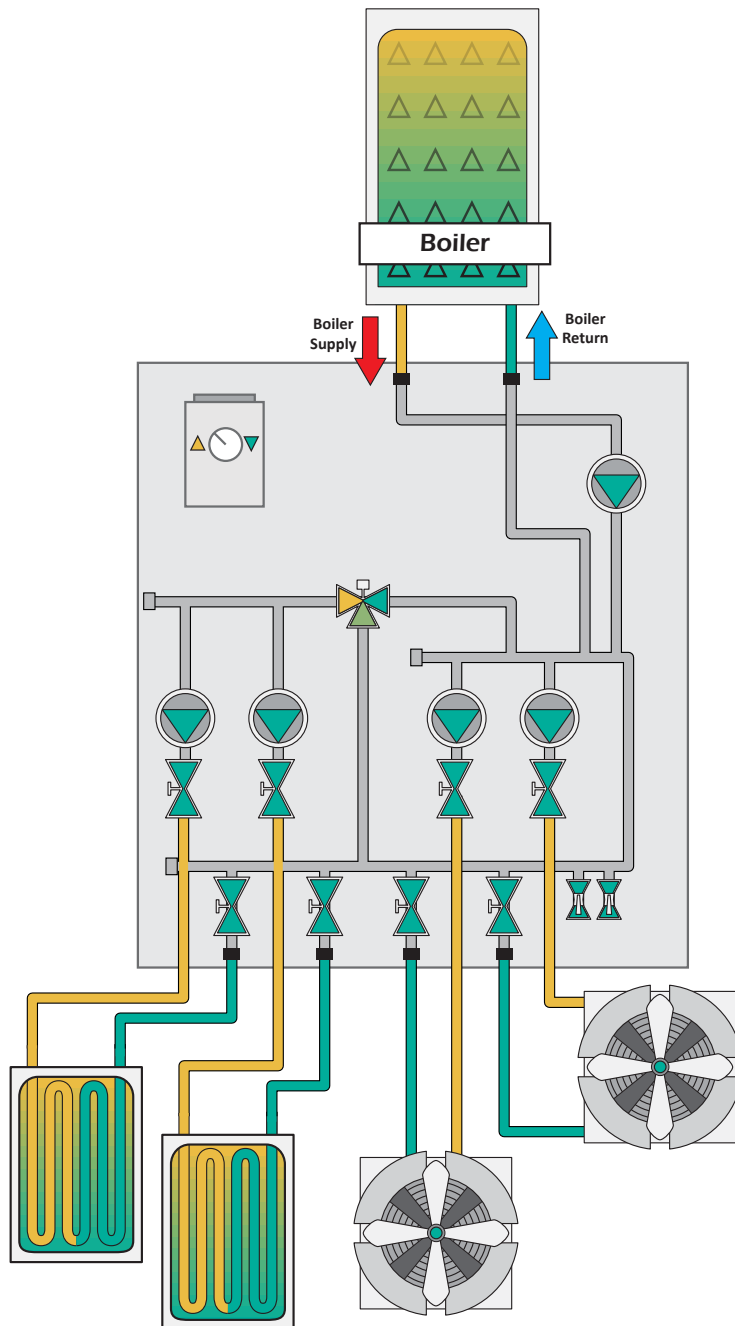

UPS 15-58 3 Speed Pump

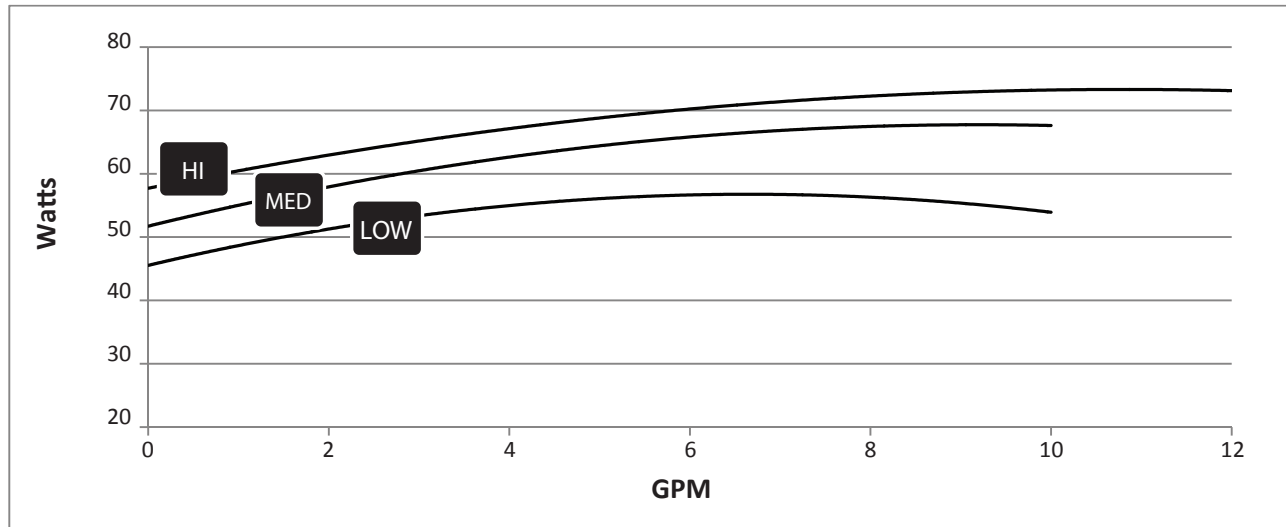
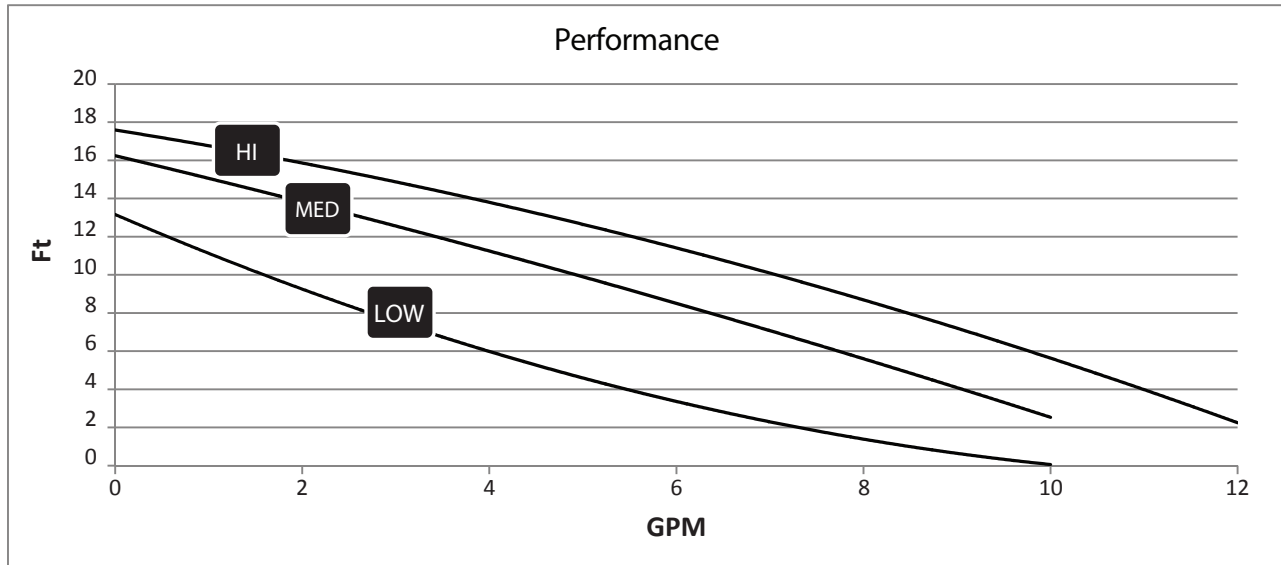

- 230° F Max fluid temp (closed system)
- 150° F Max fluid temp (open system)
- 36° F Min fluid temp
- 10 Bar Max system pressure

Approvals

- ETL
- NSF Std 61
- Annex G

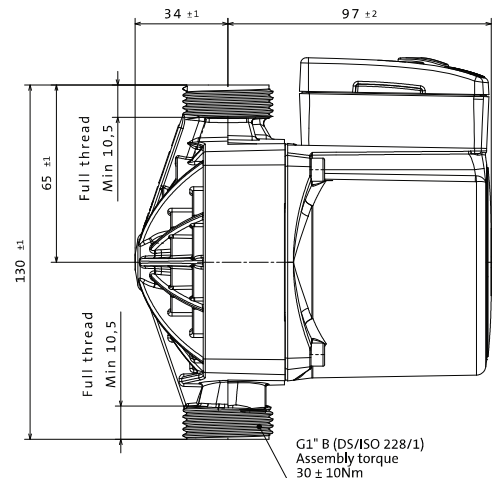
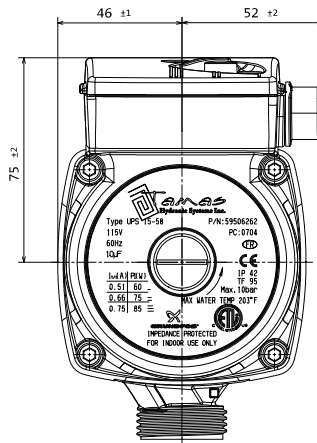

Thermostatic mixing valve (ASSE-1017 listed*)

- Anti-scald function.
- Snap-on cover for protection and to prevent unauthorized adjustment or tampering.
- Cover label for recording settings including recorded outlet temperature and date installed.
- Available temperature ranges:
 - o 70°F – 110°F (20°C - 45°C)* o 85°F – 120°F (29°C - 49°C)*
 - o 95°F – 140°F (35°C - 60°C)* o 85°F – 160°F (30°C - 70°C)* (¾" only)
- Available connections
 - o Threaded body (FPT). o Union solder.
 - o Union solder w/ 1 check valve. o Union solder c/w 2 check valves.
 - o Union CPVC. o Compression (¾" only).
- Maximum working pressure: 150 psi (10 bar)**.
- Maximum system differential pressure between hot and cold: 44 psi (3 bar).
- Maximum system differential pressure: 72 psi (5 bar).
- Maximum hot water inlet temperature: 194°F (90°C).
- Minimum required flow***: 0.5 US gpm.

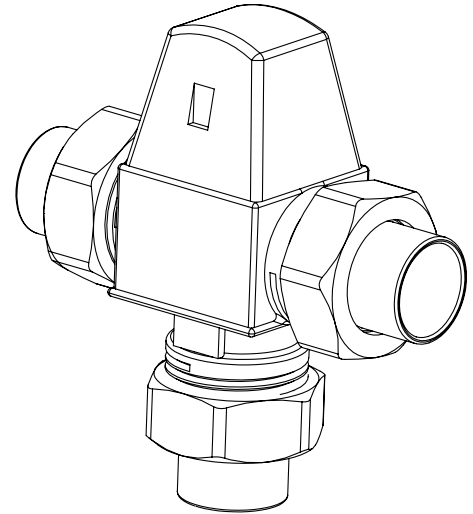

The thermostatic mixing valve will provide a mixed water temperature according to the table below. The outlet temperatures stated are approximate, based on given hot water supply temperature and a cold water supply of 50°F (10°C). For other cold water temperatures correct the outlet temperature by 1°F for every 10°F (or 1°C for every 10°C) deviation from 50°F (10°C), up or down.

Hot Water Temperature	70°F – 110°F						85°F – 120°F						95°F – 140°F					
	1	2	3	4	5	6	1	2	3	4	5	6	1	2	3	4	5	6
120°F	67	74	81	87	94	109	80	90	97	102	107	115	95	106	115	124	131	136
140°F	68	75	82	90	97	113	81	91	99	104	109	117	97	108	117	126	133	140
160°F	69	76	84	92	100	118	82	93	100	106	112	118	99	109	118	127	135	145
180°F	70	77	86	95	102	122	82	95	102	108	114	120	100	111	120	129	136	149

* Only ranges 85-120°F and 95-140°F are listed to ASSE-1017 standard
 **Max. working pressure for CPVC: 80 psi (5.5 bar)
 ***For Correct temperature control

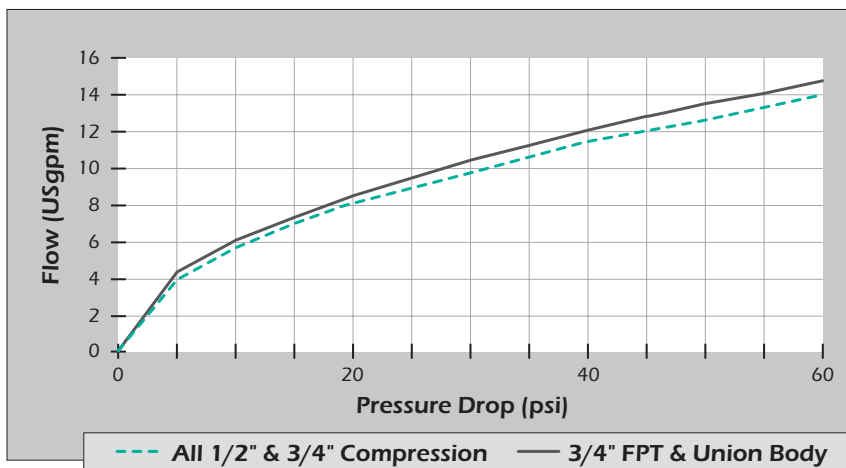

Wiring

All electrical wiring to the panel (including grounding) must conform to local electrical codes and/or National Electrical Code, ANS/NFPA No. 70-latest edition, or the Canadian Electrical Code, C22.1- Part 1.

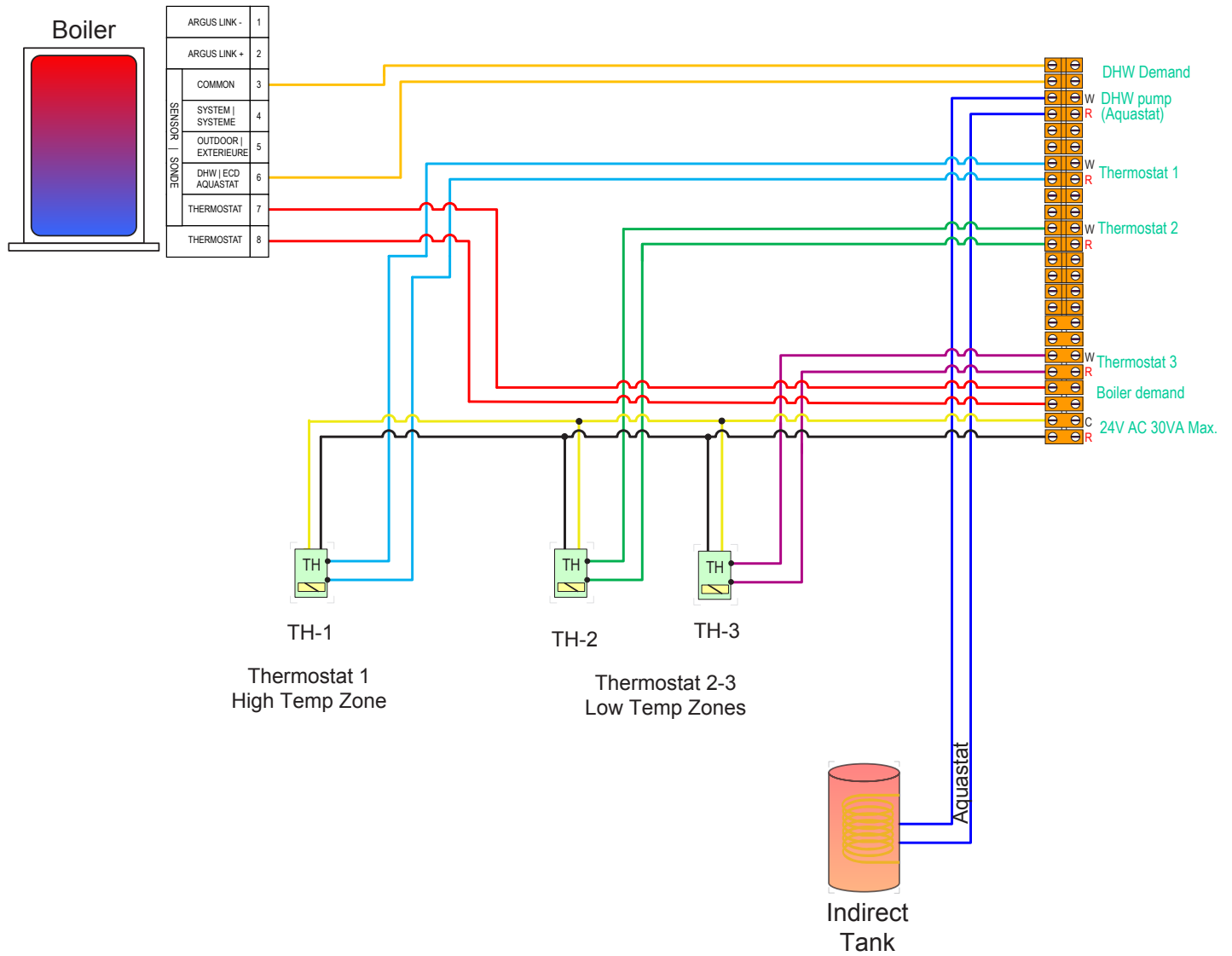

Thermostat 1-2

Connect the thermostat for a space heating zone to the terminal block on the Tamas Panel. Do not supply 24V power to the thermostat circuits or attempt to supply 24V AC for any other application.

For the thermostats that require continuous 24V AC power source, connect the thermostat power input to the 24V AC terminal on the Tamas Panel.

2 Wire Thermostat

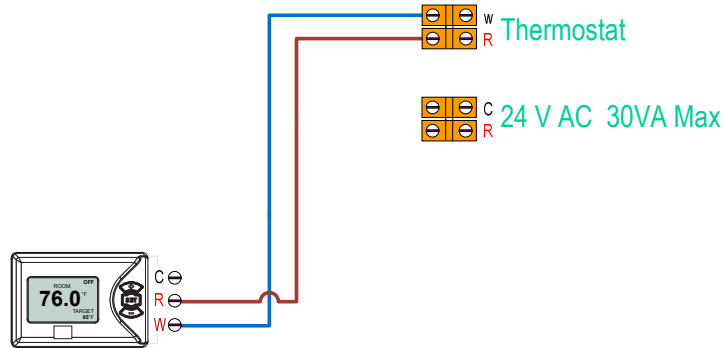

3 Wire Thermostat

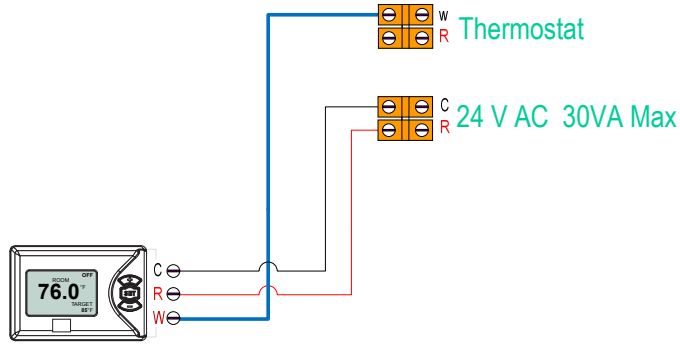

4 Wire Thermostat

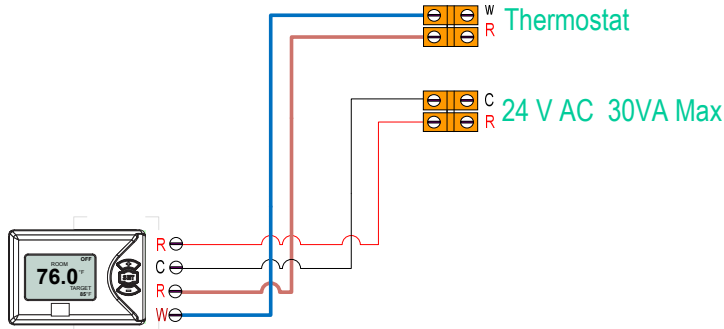

System Filling Procedure

1. Disconnect power from the Tamas Hydronic panel
2. Install recommended purging valve on return zone line.(field supplied see below drawing)
3. Close all isolation valves to the zones
4. Begin filling the panel through the provided hose bib connection on the panel
5. Open the return isolation valve on the panel
6. Begin filling the system
7. Slowly open the purging valve on the return side of the zone line to let the air out of the system
8. After the above procedure is done, close the air purging valve
9. Finally close all the valves to isolate the zone from the panel before moving on to the next zone.
10. Repeat this procedure based on the amount of zones on the board
11. Once all the zones have been purged, you can open all the isolation valves

IMPORTANT This procedure applies to filling the system one zone at a time.

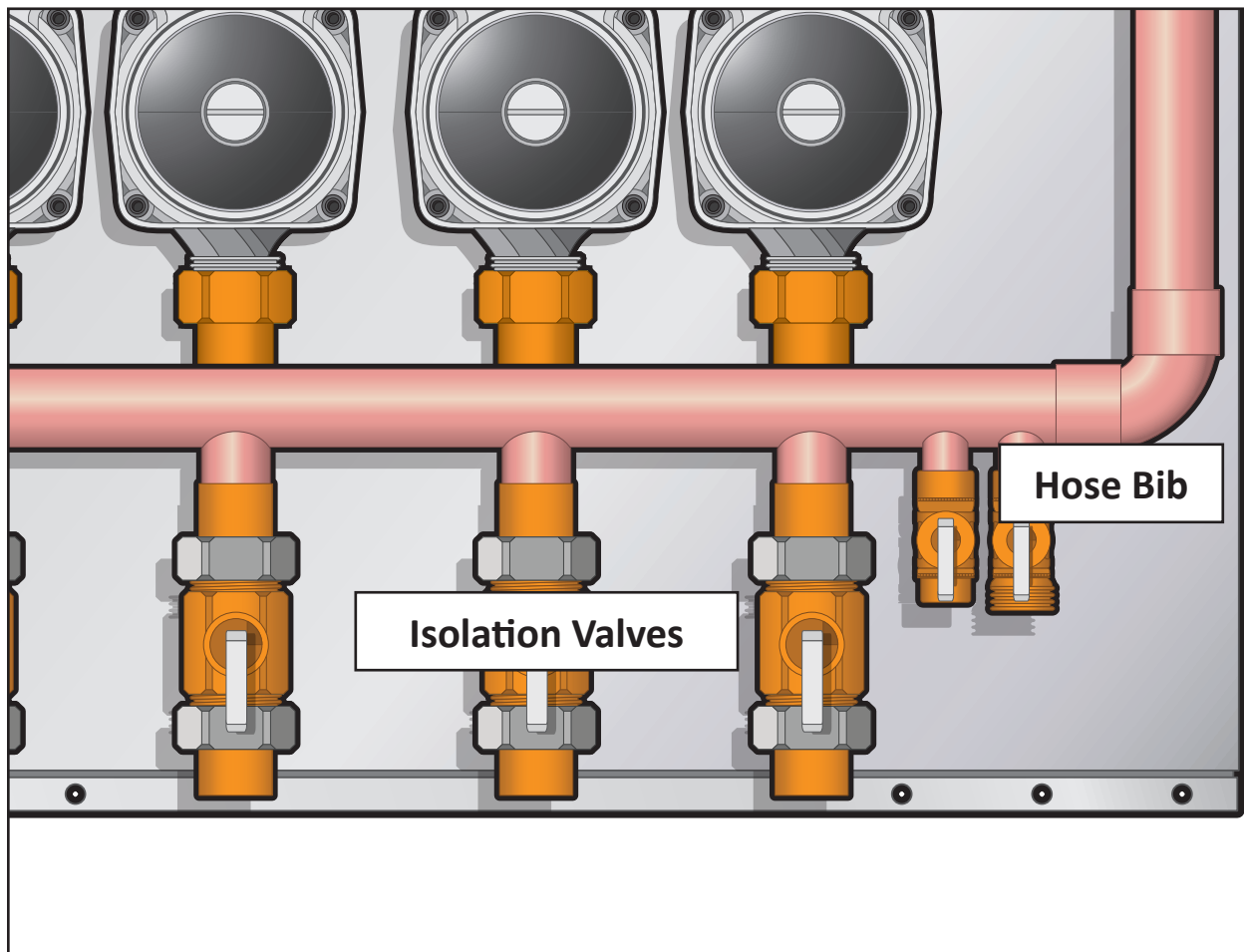



Limited Warranty

Tamas Hydronic Systems Inc. warrants each of its products to be free from defects in workmanship and materials under normal use and service for a period of 24 months from a Tamas Hydronic Systems inc. authorized Dealer.

If the product proves to be defective within the applicable warranty period, Tamas Hydronic Systems inc. on its sole discretion will repair or replace said product. Replacement product may be new or refurbished of equivalent or better specifications, relative to the defective product. Replacement product need not be of identical design or model. Any repair or replacement product pursuant to this warranty shall be warranted for not less than 90 days from date of such repair, irrespective of any earlier expiration of original warranty period. When Tamas Hydronic Systems Inc. Provides replacement, the defective product becomes the property of Tamas Hydronic Systems Inc.

Warranty Service, within the applicable warranty period, may be obtained by contacting your nearest Tamas Hydronics Systems inc. office via the original Authorized Agent and requesting a Return Material Authorization Number (RMA #). Proof of purchase in the form a dated invoice/receipt must be provided to expedite the issuance of a Factory RMA.

After an RMA number has been issued, the defective product must be packaged securely in the original or other suitable shipping package to ensure that it will not be damaged in transit. The RMA number must be visible on the outside of the package and a copy included inside the package. The package must be mailed or otherwise shipped back to Tamas Hydronic Systems Inc. with all costs of mailing/shipping/insurance prepaid by the warranty claimant.

Any package/s returned to Tamas Hydronic Systems Inc. without an approved and visible RMA number will be rejected and shipped back to purchaser at purchaser's expense. Tamas Hydronic Systems Inc. Reserves the right, if deemed necessary, to charge a reasonable levy for costs incurred, additional to mailing or shipping costs.

Limitation of Warranties.

If the Tamas Hydronic Systems Inc. product does not operate as warranted above the purchasers sole remedy shall be, at Tamas Hydronic Systems Inc.' s option, repair or replacement. The foregoing warranties and remedies are exclusive and in lieu of all other warranties, expressed or implied, either in fact or by operation of law, statutory or otherwise, including warranties of merchantability and fitness for a particular purpose/application. Tamas Hydronic Systems Inc. neither assumes nor authorizes any other person to assume for it any other liability in connection with the sale, installation maintenance or use of Tamas Hydronic Systems Inc. products.

Tamas Hydronic Systems Inc. shall not be liable under this warranty; if its testing and examination discloses that the alleged defect in the product does not exist or was caused by the purchasers or third persons misuse, neglect, improper installation or testing, unauthorized attempts to repair or any other cause beyond the range of intended use, or by accident, fire, lightning or other hazard.

Limitation of Liability.

In no event will Tamas Hydronic Systems Inc. be liable for any damages, including loss of data, loss of profits, costs of cover or other incidental, consequential or indirect damages arising out of the installation, maintenance, commissioning, performance, failure or interruption of a Tamas Hydronic Systems Inc. product, however caused and on any theory of liability. This limitation will apply even if Tamas Hydronic Systems Inc. has been advised of the possibility of such damage.

Local Law.

This limited warranty statement gives the purchaser specific legal rights. The purchaser may also have other rights which vary from state to state in the United States, from Province to Province in Canada and from Country to Country elsewhere in the world.

To the extent this Limited Warranty Statement is inconsistent with local law, this statement shall be deemed modified to be consistent with such local law. Under such local law, certain disclaimers and limitations of this statement may not apply to the purchaser. For example, some states in the United States, as well as some governments outside the United States (including Canadian Provinces), may:

Preclude the disclaimers and limitations in this statement from limiting the statutory rights of a consumer (e.g. United Kingdom);

Otherwise restrict the ability of a manufacturer to enforce such disclaimers or limitations; or

Grant the purchaser additional warranty rights which the manufacturer cannot disclaim, or not allow limitations on the duration of implied warranties.

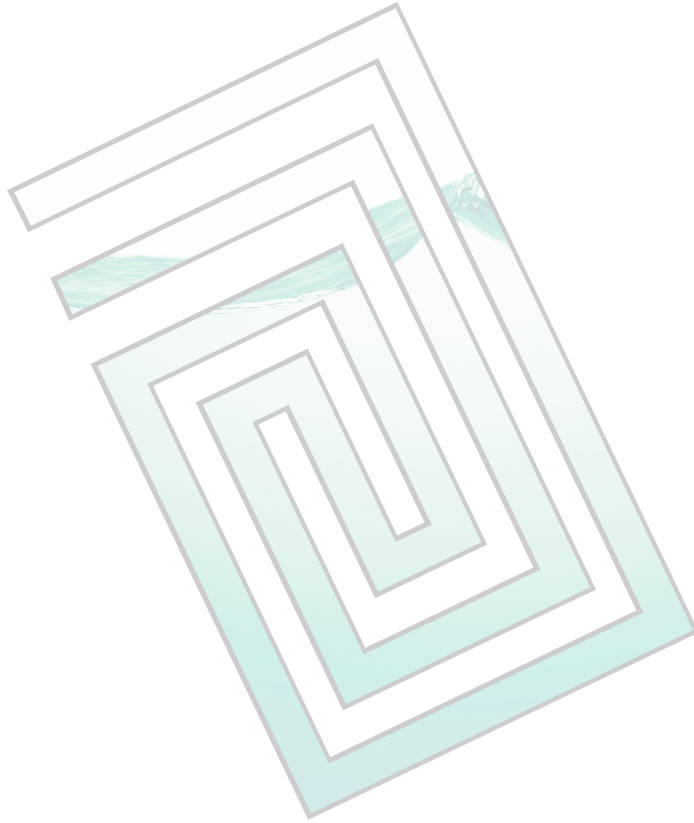

Custom, Reliable Hydronic Systems

Tamas Hydronic Systems Inc.
4516 112 Avenue SE
Calgary, Alberta T2C 2K2

Phone: 1 (403) 279 0020
Fax: 1 (403) 279 0747
info@tamashydronic.com



[/TamasHydronicSystems](#)



[/TamasHydronic](#)



[/company/tamas-hydronic-systems](#)