

Air Eliminator Series

Installation and Commissioning Guide

Introduction.....	3
Components.....	4-5
Operation.....	6
Technical Data.....	7-10
Wiring.....	11-12
Commissioning.....	13
Warranty.....	14

This User Guide is Applicable to:

Air Eliminator Panels

T-BO-OD-1200	Air Eliminator Boiler Panel with (1) 15-58 Boiler Pump, (2) 15-58 Zone Pumps, (1) Air Separator and White Enclosure
T-BO-OD-1300	Air Eliminator Boiler Panel with (1) 15-58 Boiler Pump, (3) 15-58 Zone Pumps, (1) Air Separator and White Enclosure
T-BO-OD-1400	Air Eliminator Boiler Panel with (1) 15-58 Boiler Pump, (4) 15-58 Zone Pumps, (1) Air Separator and White Enclosure
T-BO-OD-1500	Air Eliminator Boiler Panel with (1) 15-58 Boiler Pump, (5) 15-58 Zone Pumps, (1) Air Separator and White Enclosure
T-BO-OD-1600	Air Eliminator Boiler Panel with (1) 15-58 Boiler Pump, (6) 15-58 Zone Pumps, (1) Air Separator and White Enclosure
T-BO-OD-2200	Air Eliminator Boiler Panel with (1) 26-99 Boiler Pump, (2) 15-58 Zone Pumps, (1) Air Separator and White Enclosure
T-BO-OD-2300	Air Eliminator Boiler Panel with (1) 26-99 Boiler Pump, (3) 15-58 Zone Pumps, (1) Air Separator and White Enclosure
T-BO-OD-2400	Air Eliminator Boiler Panel with (1) 26-99 Boiler Pump, (4) 15-58 Zone Pumps, (1) Air Separator and White Enclosure
T-BO-OD-2500	Air Eliminator Boiler Panel with (1) 26-99 Boiler Pump, (5) 15-58 Zone Pumps, (1) Air Separator and White Enclosure
T-BO-OD-2600	Air Eliminator Boiler Panel with (1) 26-99 Boiler Pump, (6) 15-58 Zone Pumps, (1) Air Separator and White Enclosure

*** Note:**

The following parts lists and application drawings are general samplings. Each panel configuration dictates the required components, including pump type. See the Technical Data section of the manual for specific information on each part in your particular variation of the Tamas Air Eliminator Panel.

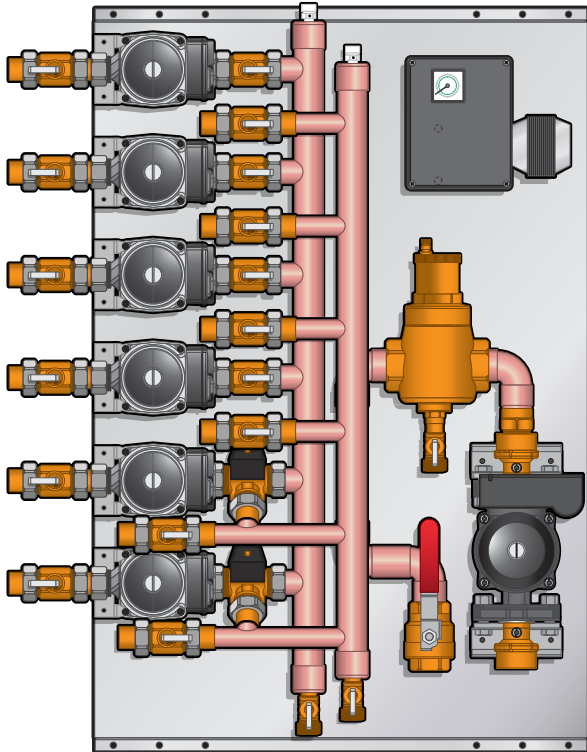

T-BO-0D-2420 Model Shown

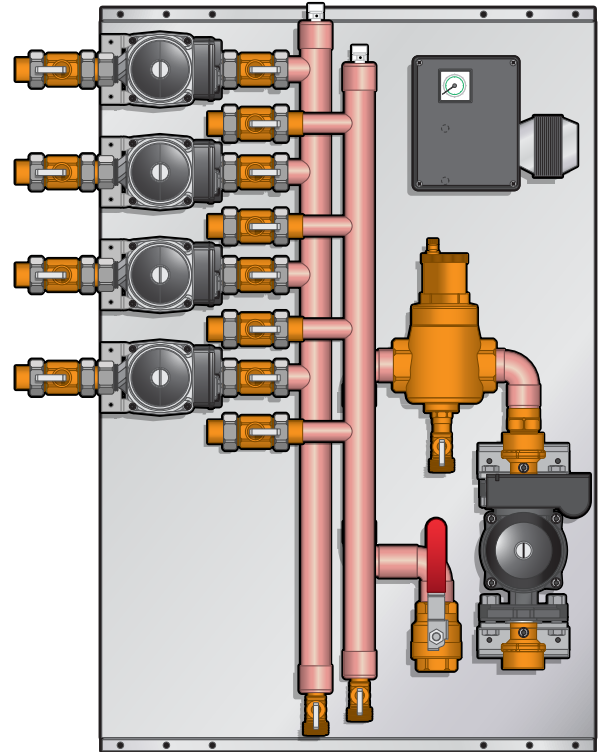

T-BO-0D-2400 Model Shown

Description

The Tamas Air Eliminator Panel is specifically designed to accommodate multiple temperature applications in the same system, up to a maximum of 6 zones of hydronic heating. This versatile panel can also be used with a dedicated condensing boiler. The 3-speed pumps used will accommodate the flow requirements for most warm and hot water requirements. A DHW priority configuration is also an option for this panel. With a compact design the panel allows for a great option for retrofit or new installs. With many configurations available the Air Eliminator panel is one of the most versatile products offered.

Installation

Prior to mounting the panel, ensure the wall is capable of supporting the weight of the panel. Ensure that an 115V receptacle is within reach of the 5-foot cord and plug.

Main Features

- Pre-designed and assembled
- Function & pressure tested
- Packaged, compact design
- Certified to CSA C22.2 No. 14-95
- Conforms to UL Standard 598A

Technical Data

- Flow Range: 0-17 US GPM
- Head Range: 0-19 Feet
- Motors: 2 Pole, Single Phase
- Max. Operating Temperature: 93°C/200°F
- Max. Ambient Temperature: 49°C/120°F
- Max. Operating Pressure: 10 Bar/145 PSI

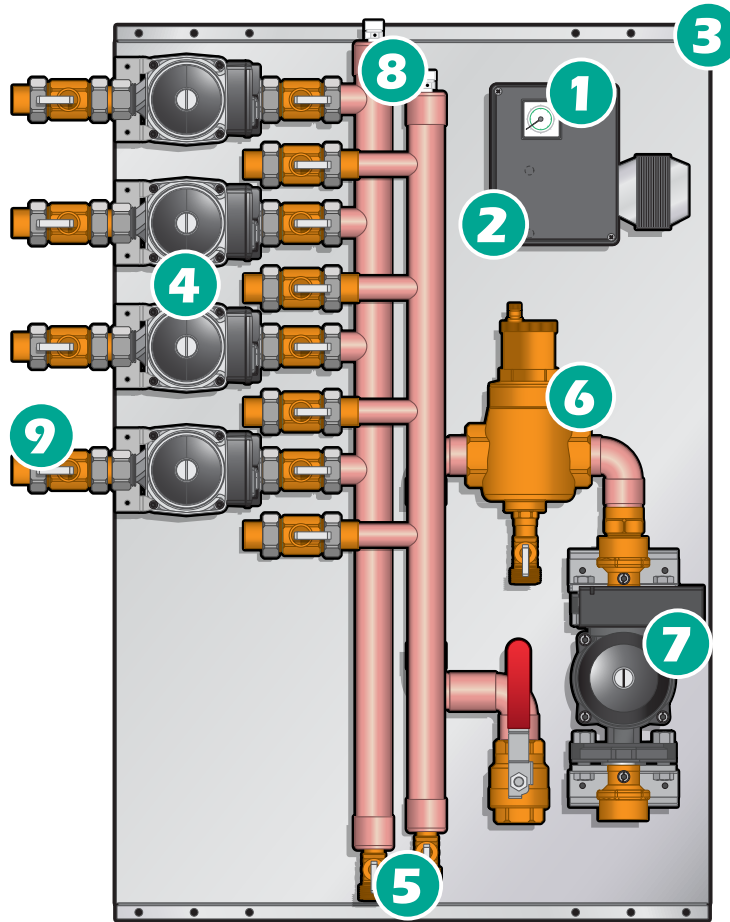

Components

1	<i>Temperature Gauge</i>	6	<i>Air Eliminator</i>
2	<i>Tamas Control Box/HBX ZON-0550 Control</i>	7	<i>Boiler Pump UPS 15-58 / UPS 26-99</i>
3	<i>Galvanized Steel Back Plate</i>	8	<i>Manual Air Vent</i>
4	<i>Zone Pumps UPS 15-58</i>	9	<i>Tamas Ball Valves</i>
5	<i>Hose Bib Hook Up</i>		

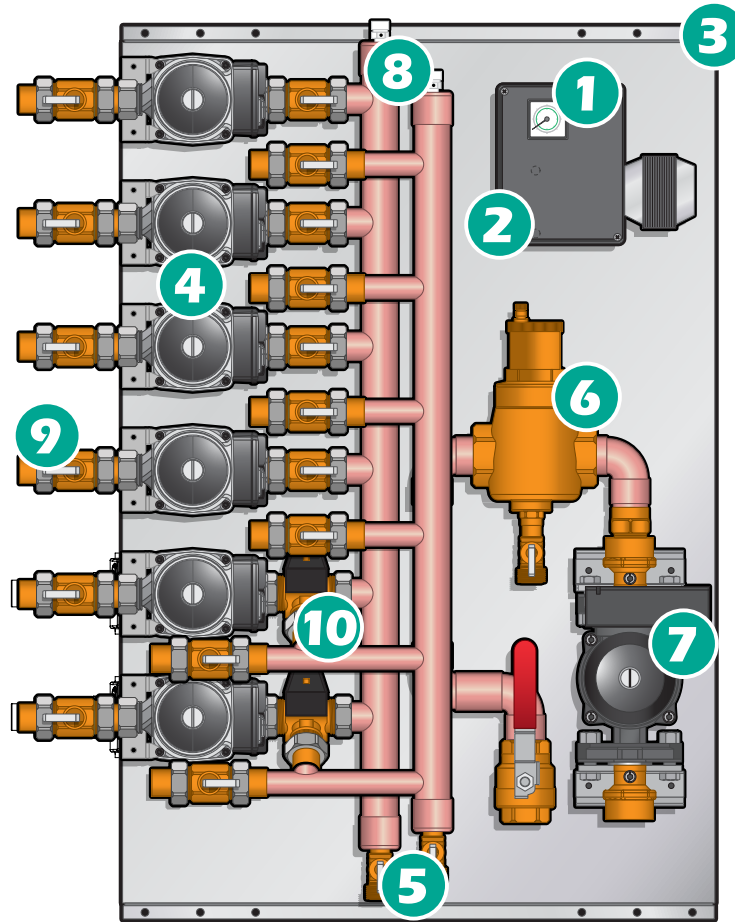

Components

1	<i>Temperature Gauge</i>	6	<i>Air Eliminator</i>
2	<i>Tamas Control Box/HBX ZON-0550 Control</i>	7	<i>Boiler Pump UPS 15-58 / UPS 26-99</i>
3	<i>Galvanized Steel Back Plate</i>	8	<i>Manual Air Vent</i>
4	<i>Zone Pumps UPS 15-58</i>	9	<i>Tamas Ball Valves</i>
5	<i>Hose Bib Hook Up</i>	10	<i>Thermostatic Mixing Valve</i>

Operation

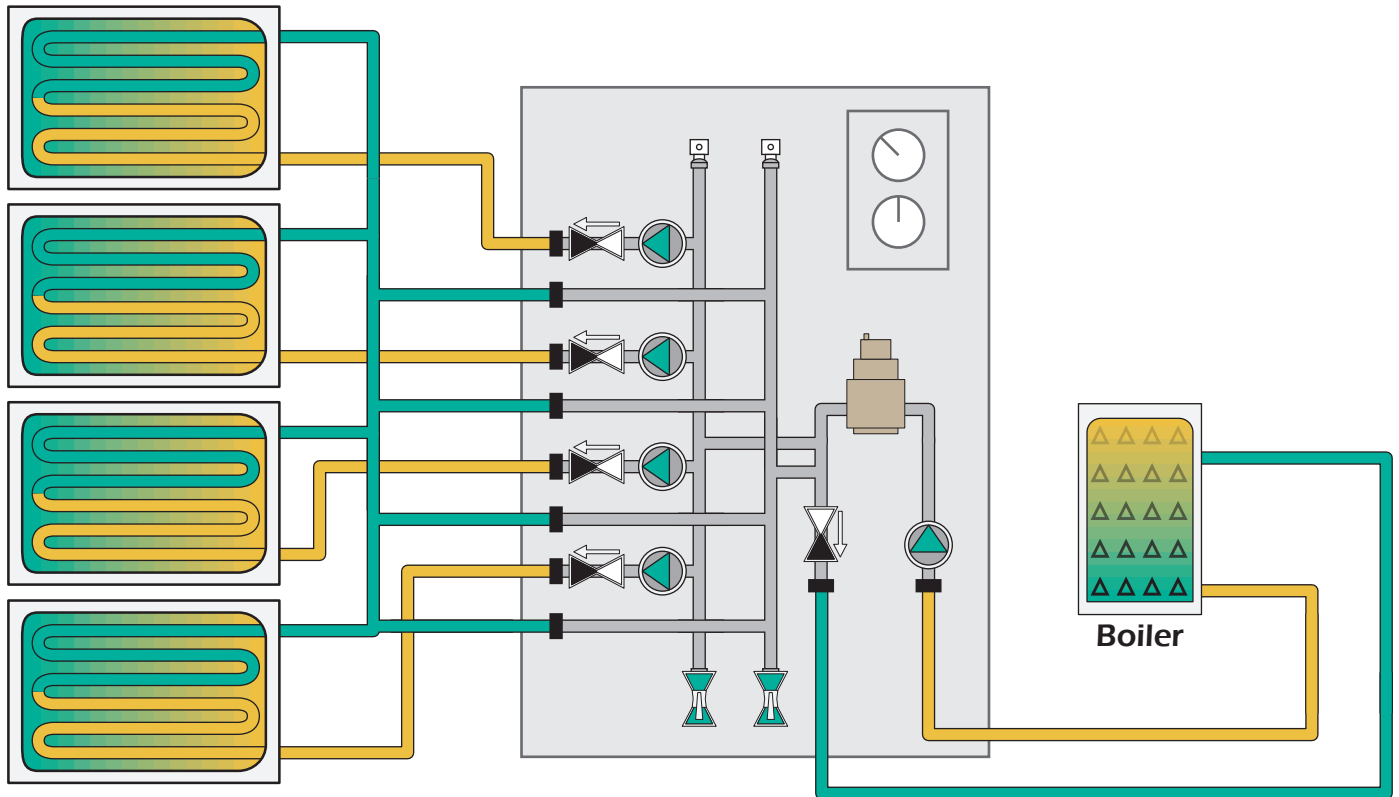

Operation of the Primary

When the Tamas Air Temperature Panel T-BO-0D-0XXX is connected to a boiler system the panel regulates the water distribution and temperature to accommodate demand.

When the room or floor temperature falls below the user's desired setting on a thermostat (sold separately), the panel initiates a signal to the boiler which will turn on the boiler pump (field supplied) and at the same time, turn on the high or low temperature pumps

When the room temperature is satisfied, the thermostat disconnects the demand to the Tamas Panel which will then end the boiler demand and turn off all pumps on the Tamas panel. (Depending on the boiler, the boiler pump will continue to run for a post purge on the boiler loop meanwhile the Tamas panel will be shut down.)

UPS 15-58 Three Speed Pump

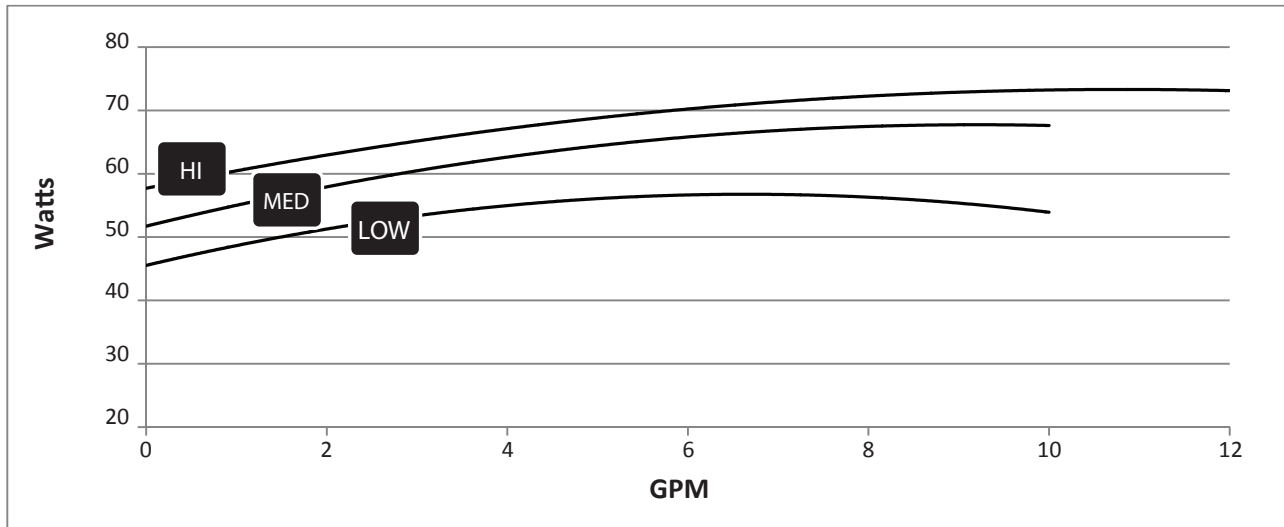
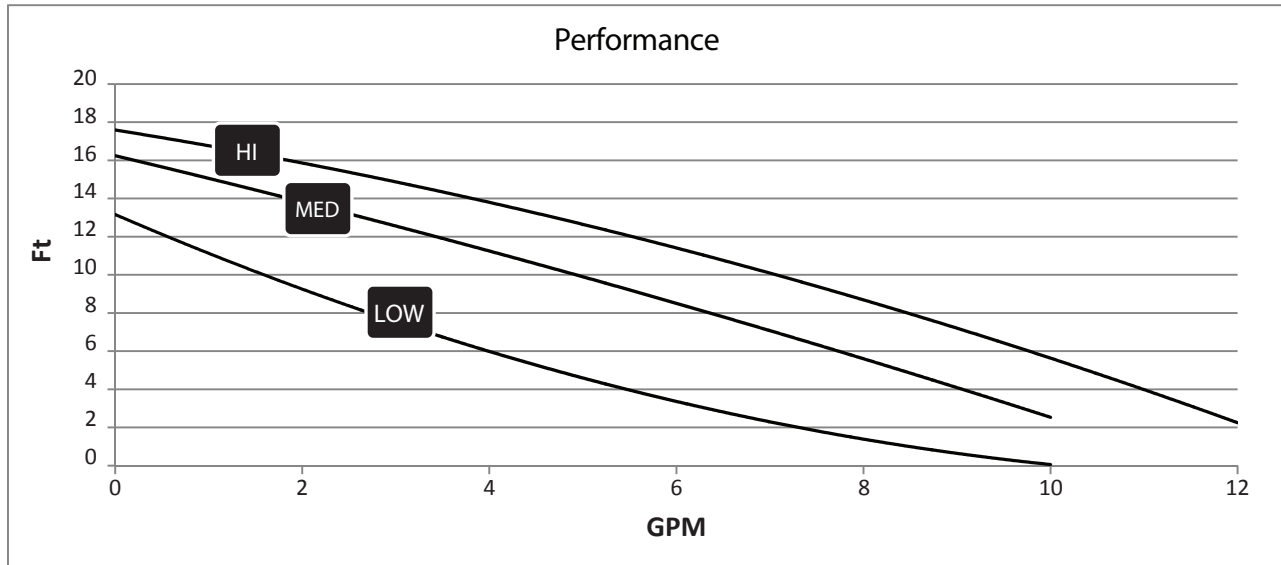

- 230° F Max fluid temp (closed system)
- 150° F Max fluid temp (open system)
- 36° F Min fluid temp
- 10 Bar Max system pressure

Approvals

- ETL
- NSF Std 61
- Annex G

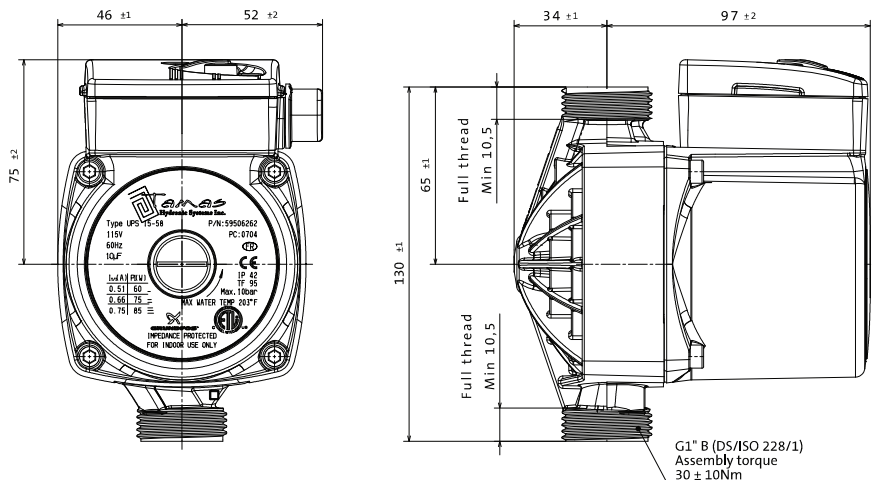

UPS 26-99 Pump

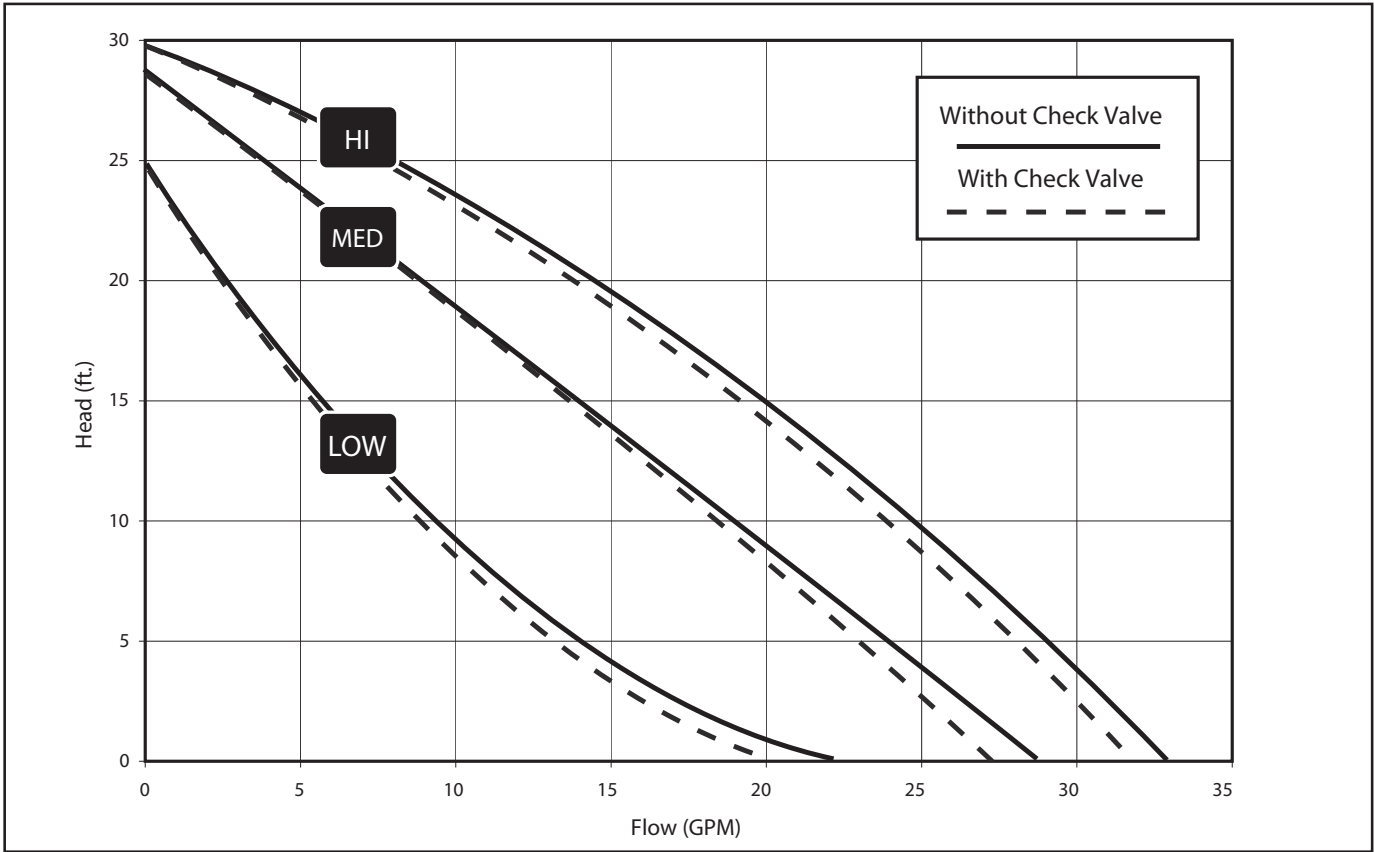

Flow range: 0 - 34 U.S. GPM
 Head range: 0 - 30 FEET
 Motors: 2 Pole, Single Phase
 Maximum fluid temperature: 230°F (110°C)
 Min. fluid temperature: 36°F (2°C)
 Maximum working pressure: 145 PSI

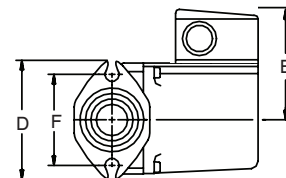
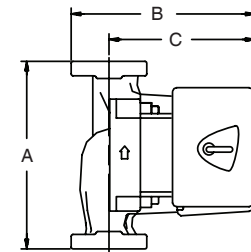

MODEL	VOLTS	AMPS	WATTS	HP	CAPACITOR
115V	Spd. 3	1.8	197	1/6	20mF/180V
	Spd. 2	1.5	179	1/6	20mF/180V
	Spd. 1	1.3	150	1/6	20mF/180V
230V	Spd. 3	0.9	196	1/6	5mF/400V
	Spd. 2	0.8	179	1/6	5mF/400V
	Spd. 1	0.7	150	1/6	5mF/400V

Model Type	A	B	C	D	E	F	Connection Type and Size	Approximate Shipping Wt. (lbs)
UPS26-99FC/BFC	6 1/2	6	4 7/8	3 1/2	3 7/16	3 5/32	GF 15/26 Flange - (2) 1/2" Dia. Bolt Holes	10.3

Dimensions

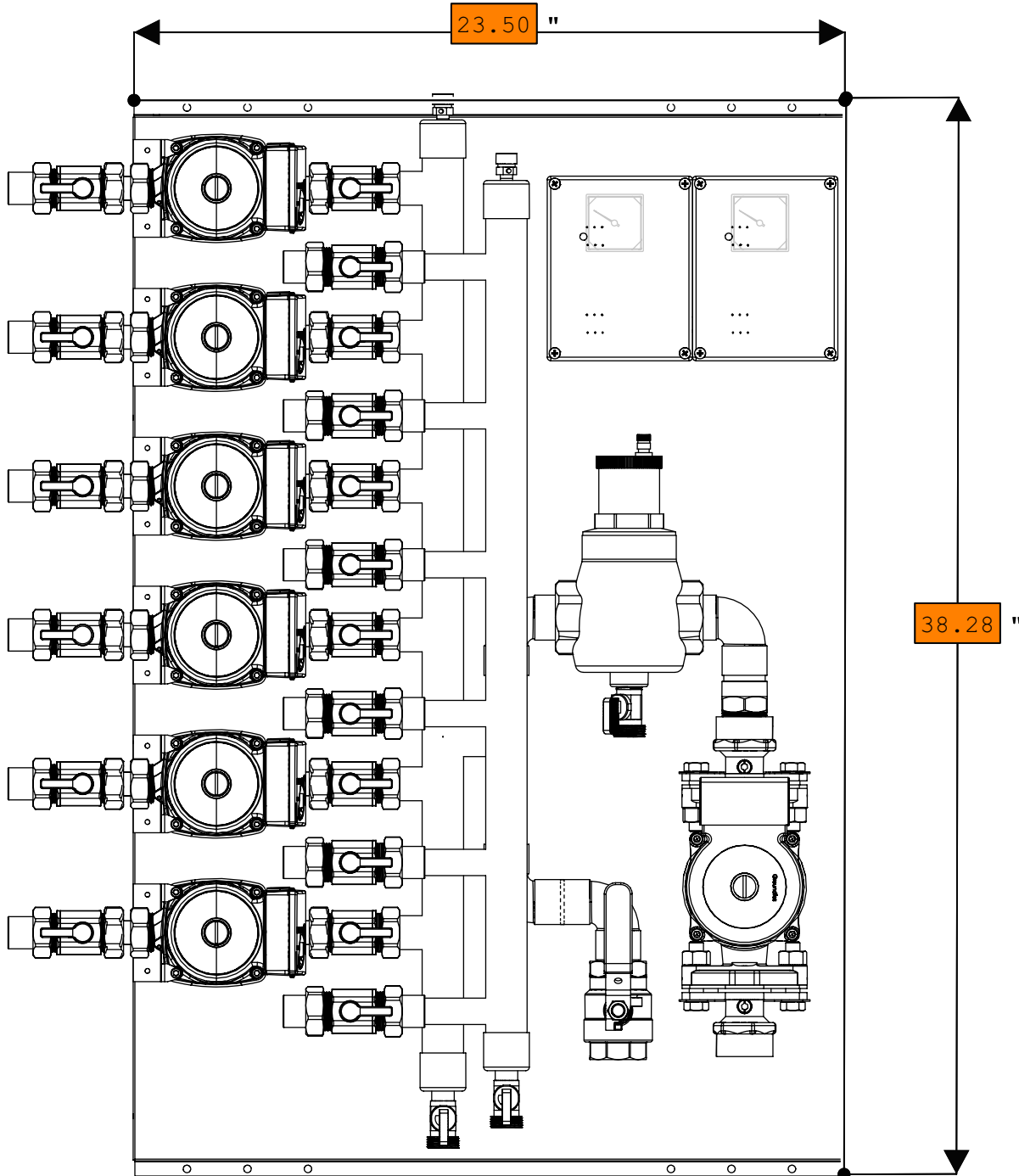

Wiring Connections

DHW Demand to Boiler: This two wire terminal can be wired back to the Boiler’s high temperature or DHW terminals. This will signal the boiler that a high temperature zone requires heating and will allow the boiler to ramp up to its domestic or high temperature set point.

Boiler Demand: This two wire terminal can be wired back to the Boiler’s thermostat or Central heating terminals. This will signal the boiler that a low temperature zone requires heating and will allow the boiler to run on its heating set point or reference its outdoor reset set point.

DHW Pump (Aquastat)/ Zone 1: If DHW is used; connect an Aquastat to the terminal DHW Pump (Aquastat)/ TH1 connection. This will make Zone 1 - DHW (Hi) Temperature and the subsequent zones will be Boiler (Low) Temperature.

If the DHW is not used, create a jumper between DHW Demand to Boiler and Boiler Demand. This will then turn DHW Pump (Aquastat) into Zone 1 with no priority.

Zone Priorities: There are a number of jumpers located on the panel terminals, labelled Priority Jumper 1 through Priority Jumper 5. When Zone 1 and/or 2 priority is jumped, it will shut down Zones 3 through 6 if there is a demand on Zone 1 or 2. This option also allows the user to prioritize one zone over the next one. This feature will shut off the zone pumps subsequent of the one with the jumper selected.

Note: Tamas Air Eliminator panels will come preset from the factory configured to the High Temperature (Jumpers In).

Power Supply: The Tamas Panel is designed to use 110V/60HZ power supply.

Thermostat/Aquastat (24V AC 30VA Max): The thermostats or Aquastat can be wired directly to the panel terminal. There are a total of 5 thermostat connections on the panel terminal (6 thermostats if DHW is not used), each corresponding to a specific zone. When the connections are closed between terminals R and C, pump number 1 will be energized. The same applies for zones 2 through 6.

Note: Thermostats are dry contact.

All electrical wiring to the panel (including grounding) must conform to local electrical codes and/or National Electrical Code, ANS/NFPA No. 70-latest edition, or the Canadian Electrical Code, C22.1- Part 1.

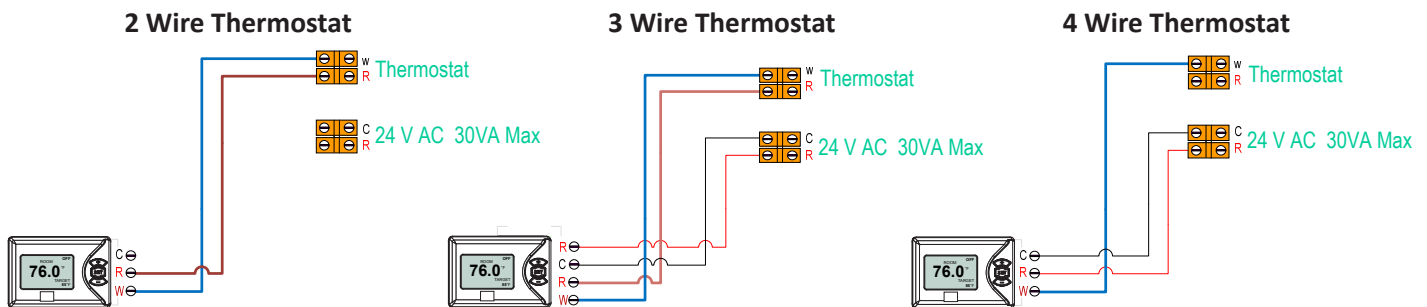

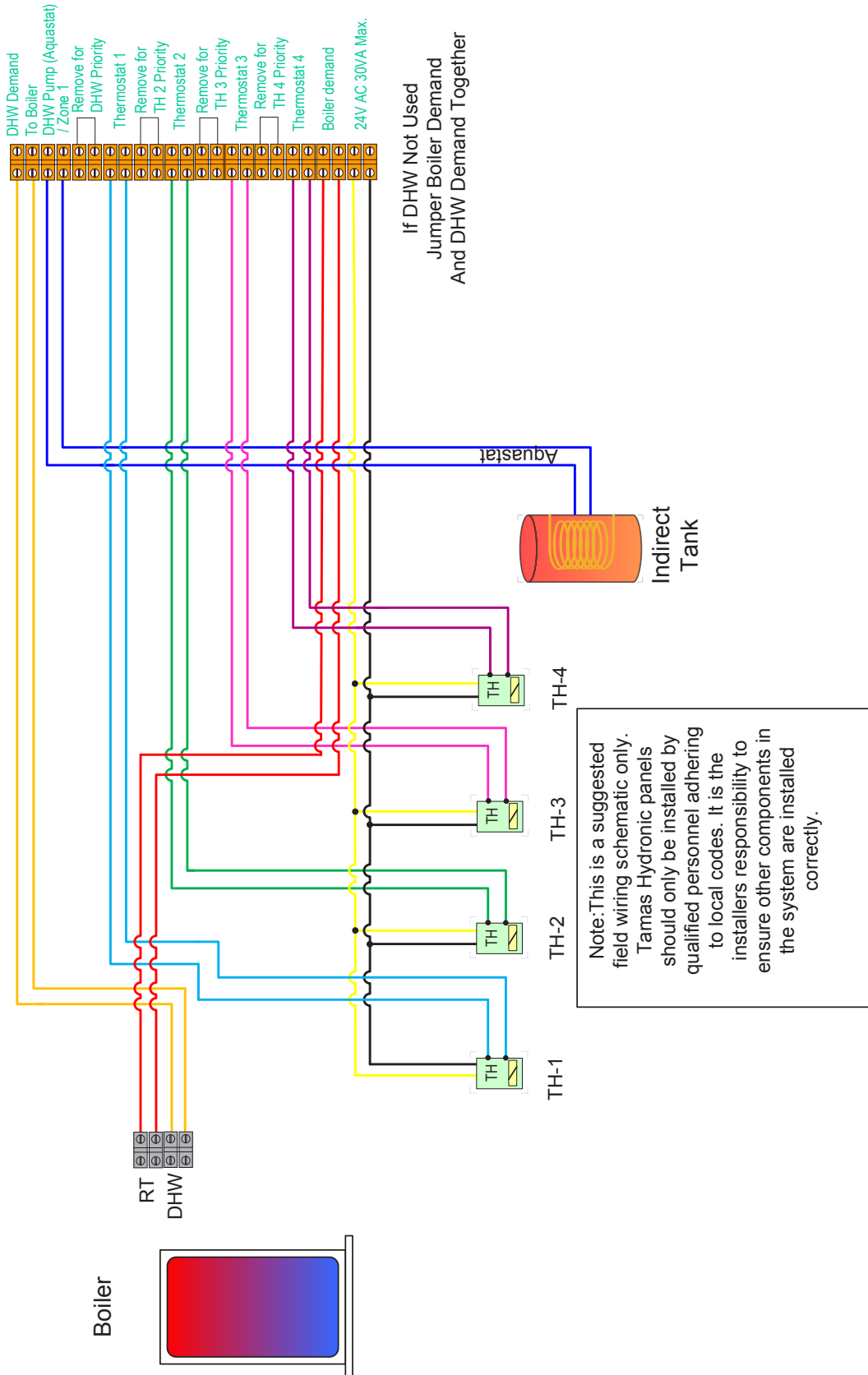

ZON-0550 Wiring Schematic

Only Applicable if the panel has the WiFi Zoning Upgrade

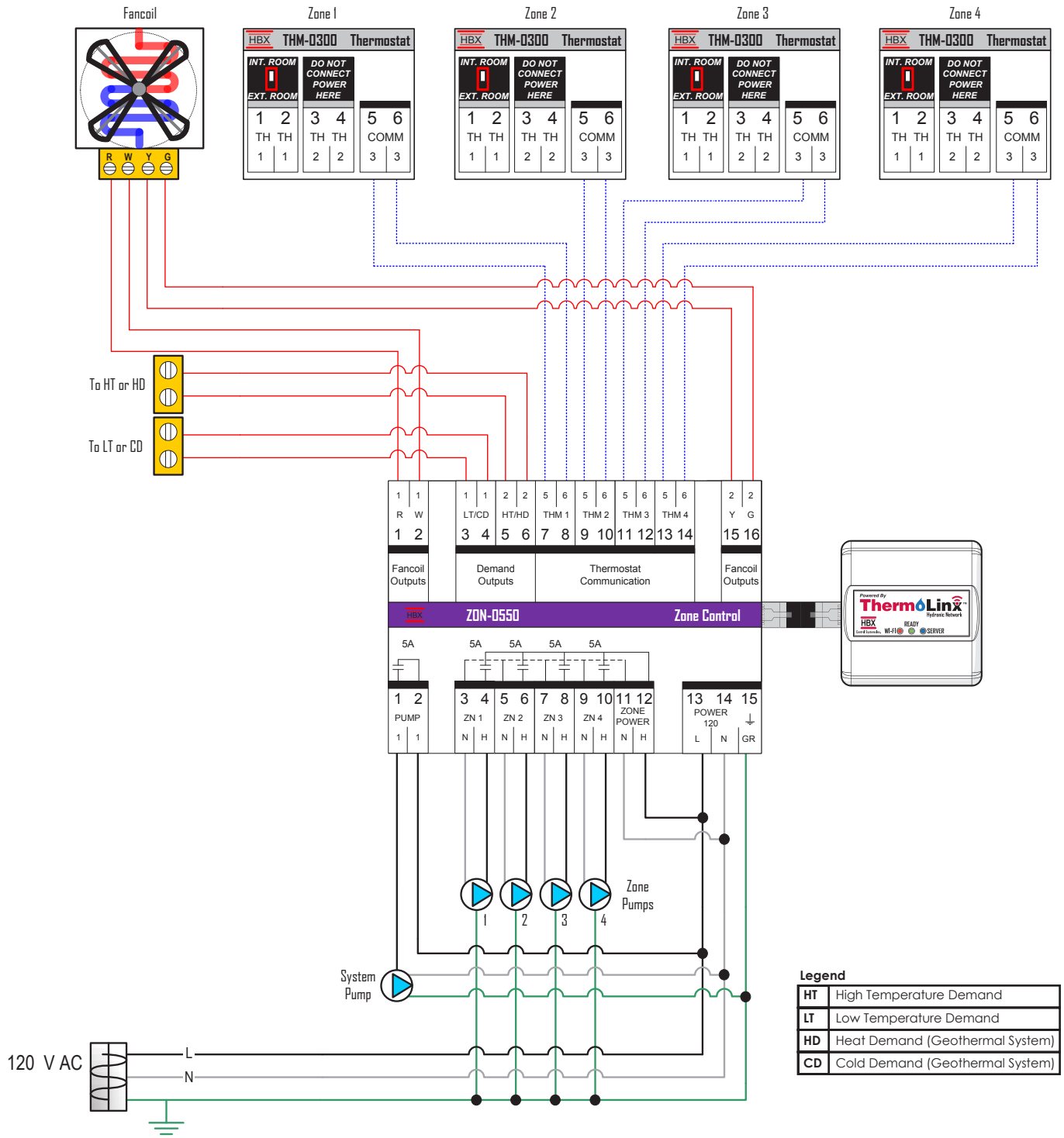

Legend

HT	High Temperature Demand
LT	Low Temperature Demand
HD	Heat Demand (Geothermal System)
CD	Cold Demand (Geothermal System)

System Filling Procedure

1. Disconnect power from the Tamas Hydronic panel
2. Close all isolation valves to the zones
3. Begin filling the panel through the provided hose bib connection on the panel
4. Open the return isolation valve on the panel
5. Begin filling the system
6. Slowly open the Manual Purging Valve on the return side of the zone line to let the air out of the system
7. After the above procedure is done, close the air Manual Purging Valve
8. Finally close all the valves to isolate the zone from the panel before moving on to the next zone.
9. Repeat this procedure based on the amount of zones on the board
10. Once all the zones have been purged, you can open all the isolation valves

IMPORTANT This procedure applies to filling the system one zone at a time.

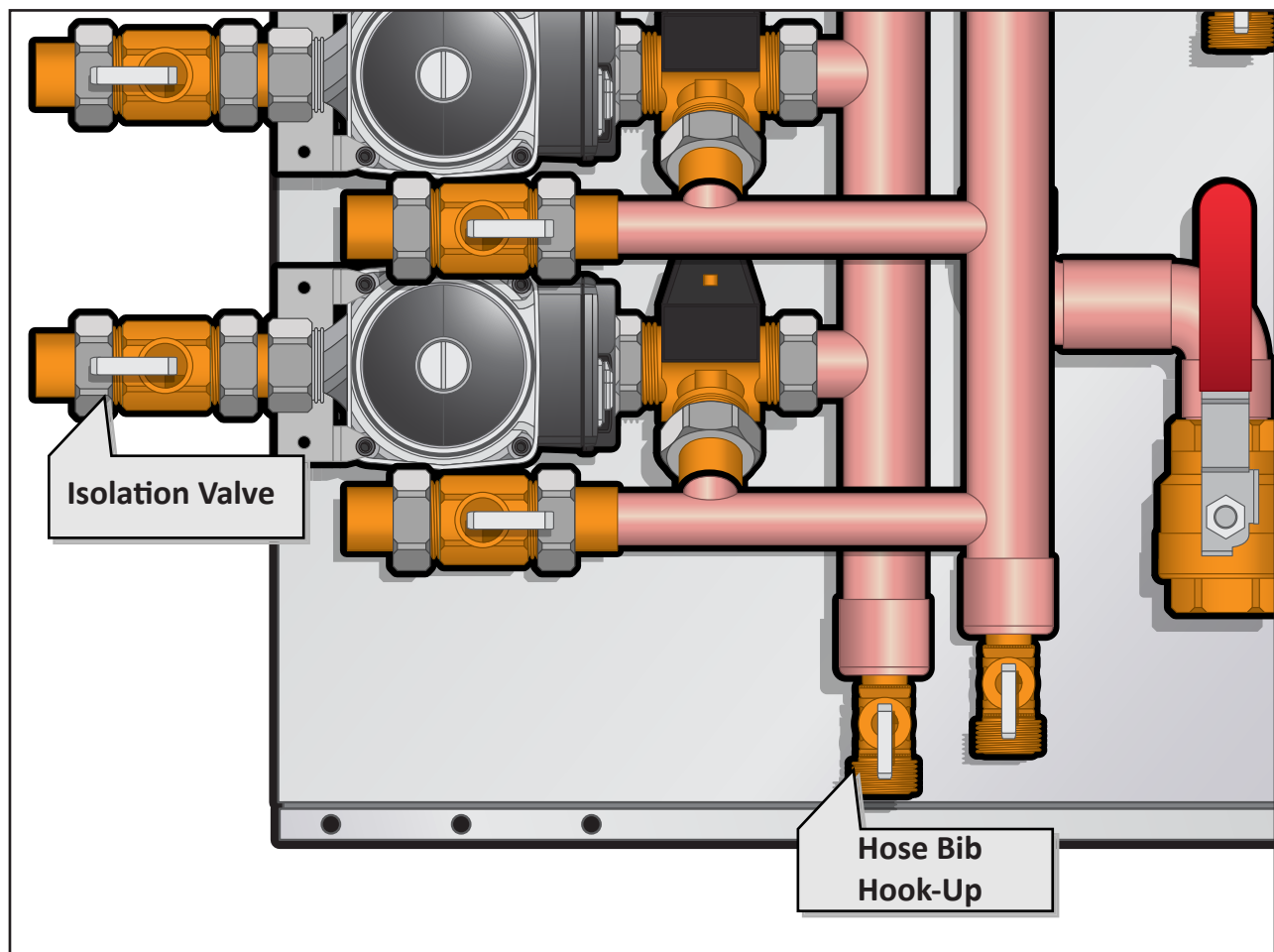

Limited Warranty

Tamas Hydronic Systems Inc. warrants each of its products to be free from defects in workmanship and materials under normal use and service for a period of 24 months from date of purchase from a Tamas Hydronic Systems inc. authorized Dealer.

If the product proves to be defective within the applicable warranty period, Tamas Hydronic Systems inc. on its sole discretion will repair or replace said product. Replacement product may be new or refurbished of equivalent or better specifications, relative to the defective product. Replacement product need not be of identical design or model. Any repair or replacement product pursuant to this warranty shall be warranted for not less than 90 days from date of such repair, irrespective of any earlier expiration of original warranty period. When Tamas Hydronic Systems Inc. Provides replacement, the defective product becomes the property of Tamas Hydronic Systems Inc.

Warranty Service, within the applicable warranty period, may be obtained by contacting your nearest Tamas Hydronics Systems inc. office via the original Authorized Agent and requesting a Return Material Authorization Number (RMA #). Proof of purchase in the form a dated invoice/receipt must be provided to expedite the issuance of a Factory RMA.

After an RMA number has been issued, the defective product must be packaged securely in the original or other suitable shipping package to ensure that it will not be damaged in transit. The RMA number must be visible on the outside of the package and a copy included inside the package. The package must be mailed or otherwise shipped back to Tamas Hydronic Systems Inc. with all costs of mailing/shipping/insurance prepaid by the warranty claimant.

Any package/s returned to Tamas Hydronic Systems Inc. without an approved and visible RMA number will be rejected and shipped back to purchaser at purchaser's expense. Tamas Hydronic Systems Inc. Reserves the right, if deemed necessary, to charge a reasonable levy for costs incurred, additional to mailing or shipping costs.

Limitation of Warranties.

If the Tamas Hydronic Systems Inc. product does not operate as warranted above the purchasers sole remedy shall be, at Tamas Hydronic Systems Inc.' s option, repair or replacement. The foregoing warranties and remedies are exclusive and in lieu of all other warranties, expressed or implied, either in fact or by operation of law, statutory or otherwise, including warranties of merchantability and fitness for a particular purpose/application. Tamas Hydronic Systems Inc. neither assumes nor authorizes any other person to assume for it any other liability in connection with the sale, installation maintenance or use of Tamas Hydronic Systems Inc. products.

Tamas Hydronic Systems Inc. shall not be liable under this warranty; if its testing and examination discloses that the alleged defect in the product does not exist or was caused by the purchasers or third persons misuse, neglect, improper installation or testing, unauthorized attempts to repair or any other cause beyond the range of intended use, or by accident, fire, lightning or other hazard.

Limitation of Liability.

In no event will Tamas Hydronic Systems Inc. be liable for any damages, including loss of data, loss of profits, costs of cover or other incidental, consequential or indirect damages arising out of the installation, maintenance, commissioning, performance, failure or interruption of a Tamas Hydronic Systems Inc. product, however caused and on any theory of liability. This limitation will apply even if Tamas Hydronic Systems Inc. has been advised of the possibility of such damage.

Local Law.

This limited warranty statement gives the purchaser specific legal rights. The purchaser may also have other rights which vary from state to state in the United States, from Province to Province in Canada and from Country to Country elsewhere in the world.

To the extent this Limited Warranty Statement is inconsistent with local law, this statement shall be deemed modified to be consistent with such local law. Under such local law, certain disclaimers and limitations of this statement may not apply to the purchaser. For example, some states in the United States, as well as some governments outside the United States (including Canadian Provinces), may:

Preclude the disclaimers and limitations in this statement from limiting the statutory rights of a consumer (e.g. United Kingdom);

Otherwise restrict the ability of a manufacturer to enforce such disclaimers or limitations; or

Grant the purchaser additional warranty rights which the manufacturer cannot disclaim, or not allow limitations on the duration of implied warranties.

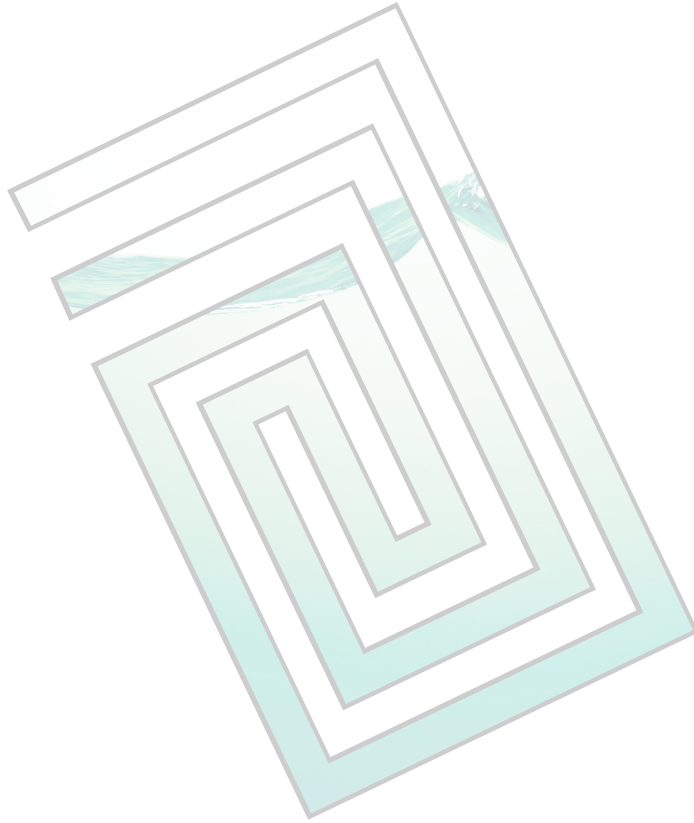

Custom, Reliable Hydronic Systems

Tamas Hydronic Systems Inc.
4516 112 Avenue SE
Calgary, Alberta T2C 2K2

Phone: 1 (403) 279 0020
Fax: 1 (403) 279 0747
info@tamashydronic.com



/TamasHydronicSystems



/TamasHydronic



/company/tamas-hydronic-systems