

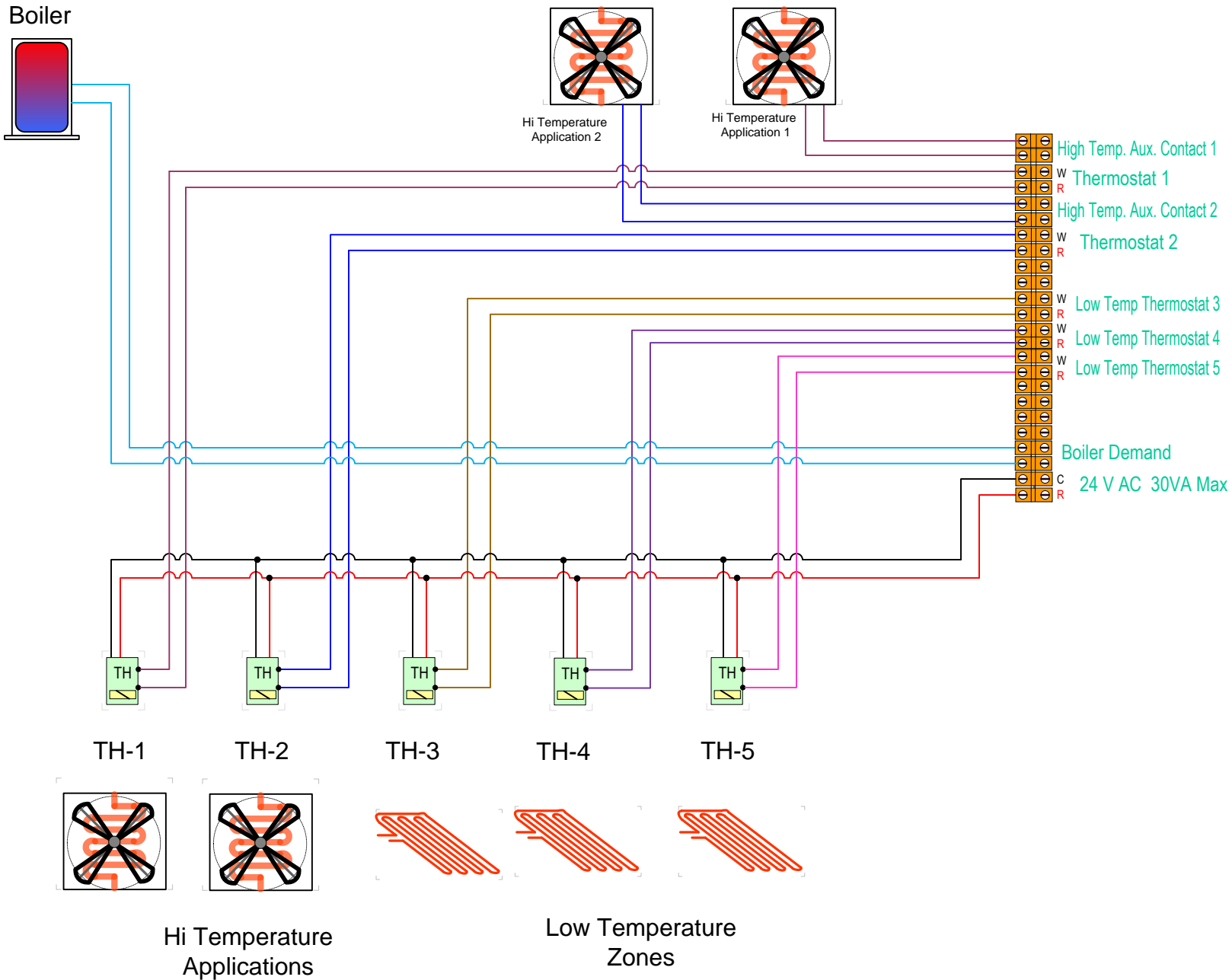

Field Wiring for T-HL-TP-0230

See reverse for Thermostat Wiring Options



Notes:
 This is not an engineered drawing and does not necessarily include all the components for an entire system. It is intended as a representative sample of how the control may be wired for a sample application. It is the responsibility of the installer to seek professional advice and/or install the the system to meet all necessary codes for the jurisdiction of the actual installation.

Title

Date:

Drawn:





Thermostat Wiring Options

2 Wire Thermostat

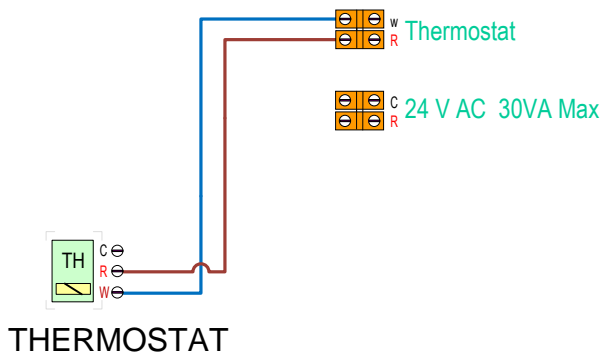

3 Wire Thermostat

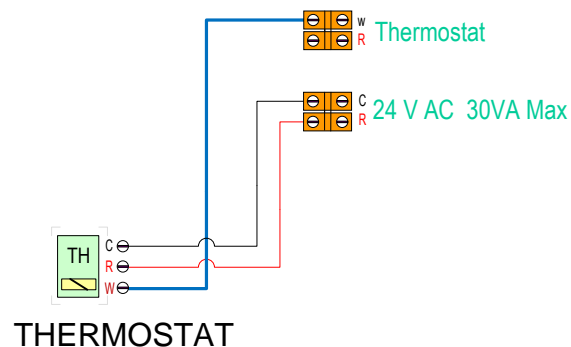

See reverse for
Thermostat Wiring Options

4 Wire Thermostat

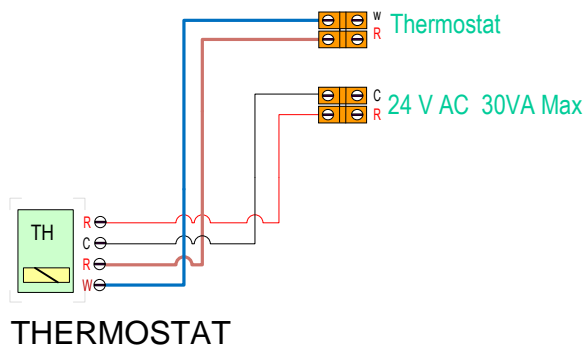

Notes:

This is not an engineered drawing and does not necessarily include all the components for an entire system. It is intended as a representative sample of how the control may be wired for a sample application. It is the responsibility of the installer to seek professional advice and/or install the the system to meet all necessary codes for the jurisdiction of the actual installation.

Title

Date:

Drawn:

